

ETABLIS

WORKBENCHES



FR

- Établis ergonomique et confortable.
- Disponibles avec/sans roues.
- Disponibles avec/sans pieds réglables (en hauteur).
- Préparé pour le montage de 1 à 3 tiroirs (selon modèle).
- Plan de travail disponibles: galvanisée/ peint /châtaigner / MDF .
- Couleur standard bleu martelé possibilité teintes en option.

EN

- Ergonomic and comfortable workbenches.
- Available with /without wheels.
- Available with/without adjustable legs (height).
- Prepared to add 1 to 3 drawers (according to model).
- Available worktops: galvanized/painted metal sheet/chestnut wood/MDF board.
- Standard colour hammered blue possibility optional colours.

BANCOS DE TRABAJO

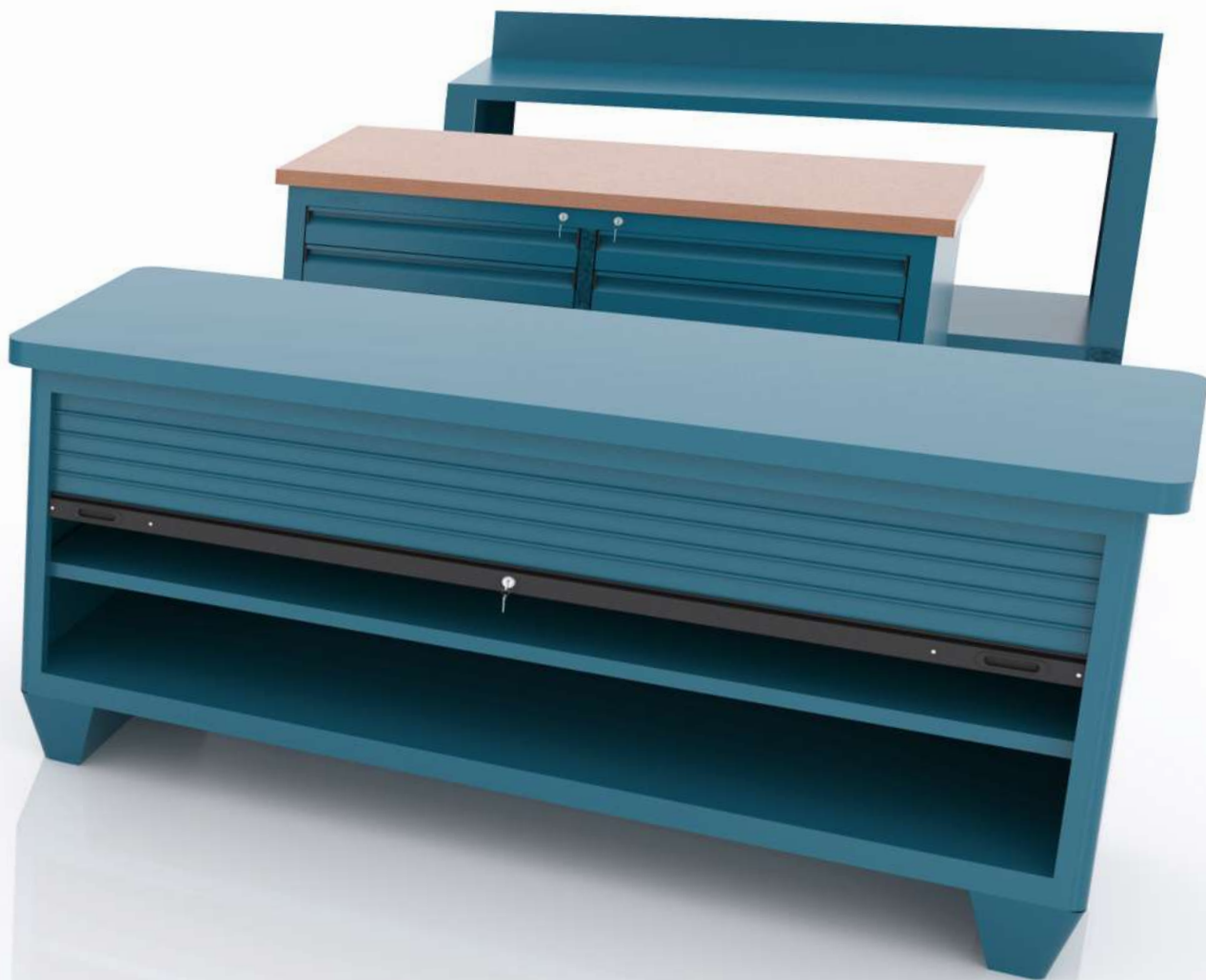

ES

- Bancos de trabajo ergonómicos y confortables.
- Disponibles con/sin ruedas.
- Disponibles con/sin patas graduables (en altura).
- Preparados para la fijación de 1 a 3 cajones (según modelo).
- Encimeras disponibles: chapa galvanizada/chapa pintada, madera de castaño/tablero de DM.
- Color estándar azul martelé posibilidad colores en opción.



SERIE 111 ref. 111 10 / 111 15 / 111 20

Banco de trabajo modular.
Établis modulaire.
Modular workbench.



SERIE 111 20

SERIE 111 15

SERIE 111 10

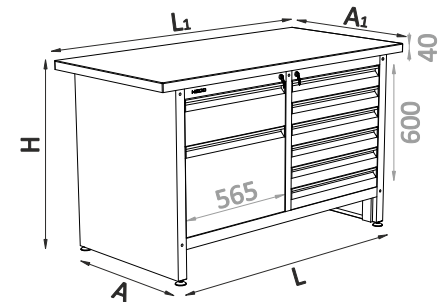

OPCIONAL OPTION OPTION

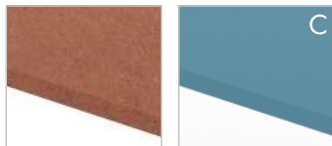

D, M
MDF
MDF

Chapa
Tôle
Metal

e 40 mm

PIES PIEDS STANDS



Base redonda regulable en altura.
Base ronde réglable en hauteur.
Height-adjustable round base.

		L x A x H (mm)	L1 x A1 (mm)
111 10	100 Kg	685x730x895	1000x750
111 15	109 Kg	1320x730x895	1500x750
111 20	133,5 Kg	1945x730x895	2000x750



Cierre centralizado.
Fermeture centralisée.
Centralized closing.



Plazo de entrega 10 días laborables.
Délai de livraison 10 jours ouvrables.
Delivery time 10 working days.



e 2 mm estructura chasis / frame
encimera plan de trabajo / worktop



e 1 mm cajones tiroirs / drawers



e 0,6 mm puertas portes / doors

SERIE 111 STANDARD



Carga total repartida.
Charge totale répartie.
Total distributed load.

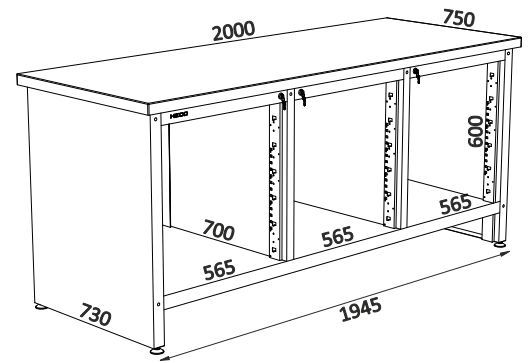
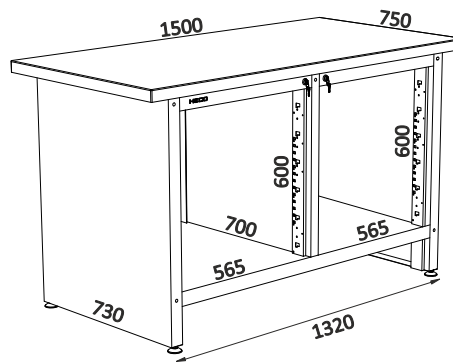
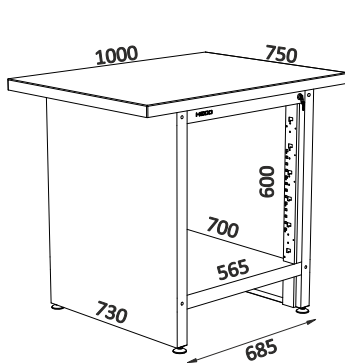

		L x A x H
111 10	100 Kg	1000x750x895
111 10 C	95 Kg	1000x750x895

		L x A x H
111 15	109 Kg	1500x750x895
111 15 C	102 Kg	1500x750x895

		L x A x H
111 20	133,5 Kg	2000x750x895
111 20 C	124,5 Kg	2000x750x895

SERIE 111 10 STANDARD



1000

Carga total repartida.
Charge totale répartie.
Total distributed load.

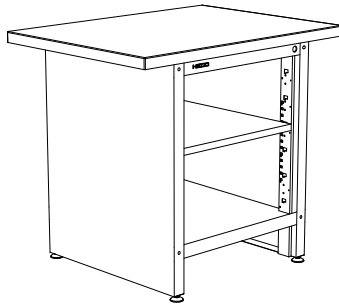

		L x A x H
111 10 01	104 Kg	1000x750x895
111 10 01 C	99 Kg	1000x750x895

accesorios / accessoires / accessories

111 BG bandeja / plateau / tray



		L x A x H
111 10 02	145 Kg	1000x750x895
111 10 02 C	140 Kg	1000x750x895

accesorios / accessoires / accessories

6x 111 C 100 cajones / tiroirs / drawers 



		L x A x H
111 10 03	127 Kg	1000x750x895
111 10 03 C	122 Kg	1000x750x895

accesorios / accessoires / accessories

3x 111 C 200 cajones / tiroirs / drawers 



		L x A x H
111 10 04	104 Kg	1000x750x895
111 10 04 C	99 Kg	1000x750x895

accesorios / accessoires / accessories

111 PG I puerta / porte / door

accesorios opcionales / accessoires optionnels / optional accessories

111 BG I bandeja / plateau / tray



		L x A x H
111 10 05	112 Kg	1000x750x895
111 10 05 C	107 Kg	1000x750x895

accesorios / accessoires / accessories

111 C 200 cajón / tiroir / drawer 

111 PP I puerta / porte / door

accesorios opcionales / accessoires optionnels / optional accessories

111 BG I bandeja / plateau / tray



		L x A x H
111 10 06	118 Kg	1000x750x895
111 10 06 C	113 Kg	1000x750x895

accesorios / accessoires / accessories

2x 111 C 100 cajones / tiroirs / drawers 

111 PP I puerta / porte / door

accesorios opcionales / accessoires optionnels / optional accessories

111 BG I bandeja / plateau / tray

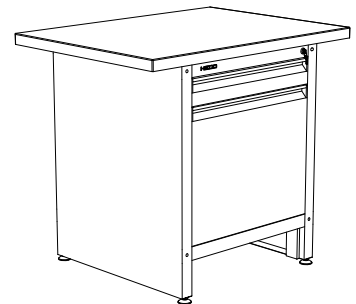

		L x A x H
111 10 07	111 Kg	1000x750x895
111 10 07 C	106 Kg	1000x750x895

accesorios / accessoires / accessories

111 C 100 cajón / tiroir / drawer 

111 PM I puerta / porte / door

accesorios opcionales / accessoires optionnels / optional accessories

111 BG I bandeja / plateau / tray



Carga total repartida.
Charge totale répartie.
Total distributed load.

1000

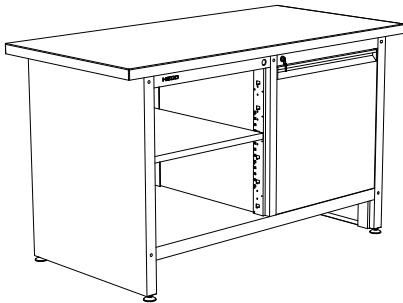

		L x A x H
111 15 01	117 Kg	1500x750x895
111 15 01 C	110 Kg	1500x750x895

accesorios / accessoires / accessories

111 BG I	estanteria / étagère / shelf
111 PG D	puerta / porte / door

accesorios opcionales / accessoires optionnels / optional accessories

111 BGCD bandeja / plateau / tray

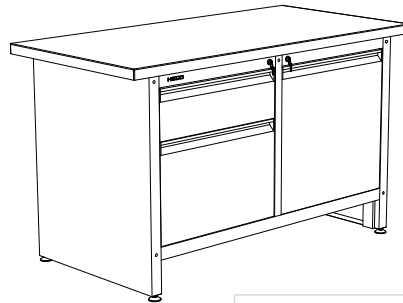

		L x A x H
111 15 02	125 Kg	1500x750x895
111 15 02 C	118 Kg	1500x750x895

accesorios / accessoires / accessories

111 C 200	cajón/ tiroir /drawer		
111 PP I	puerta / porte / door		
111 PG D	puerta / porte / door		

accesorios opcionales / accessoires optionnels / optional accessories

111 BGCD bandeja / plateau / tray

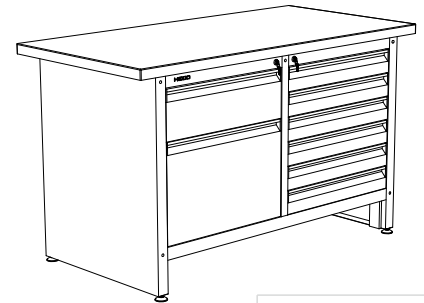

		L x A x H
111 15 03	166 Kg	1500x750x895
111 15 03 C	159 Kg	1500x750x895

accesorios / accessoires / accessories

111 C 200	cajón / tiroir /drawer		
111 PP I	puerta / porte / door		
6x 111 C 100	cajón / tiroir /drawer		

accesorios opcionales / accessoires optionnels / optional accessories

111 BGCD bandeja / plateau / tray

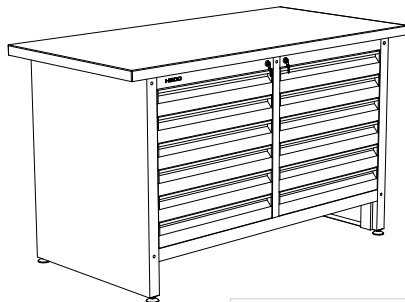

		L x A x H
111 15 04	199 Kg	1500x750x895
111 15 04 C	192 Kg	1500x750x895

accesorios / accessoires / accessories

6x 111 C 100	cajones / tiroirs /drawers		
6x 111 C 100	cajones / tiroirs /drawers		

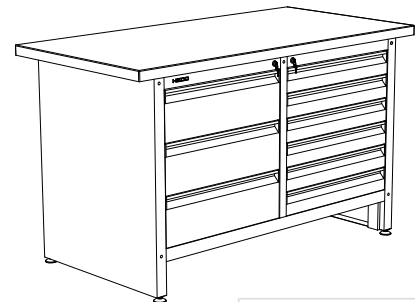

		L x A x H
111 15 05	181 Kg	1500x750x895
111 15 05 C	174 Kg	1500x750x895

accesorios / accessoires / accessories

3x 111 C 200	cajones / tiroirs /drawers		
6x 111 C 100	cajones / tiroirs /drawers		

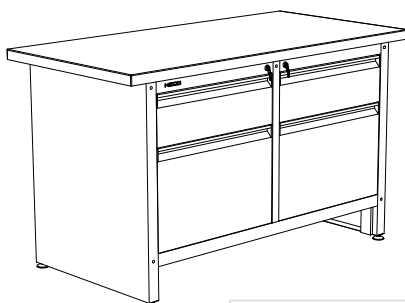

		L x A x H
111 15 06	130 Kg	1500x750x895
111 15 06 C	123 Kg	1500x750x895

accesorios / accessoires / accessories

111 C 200	cajón / tiroir /drawer		
111 PP I	puerta / porte / door		
111 C 200	cajón / tiroir /drawer		
111 PP D	puerta / porte / door		

accesorios opcionales / accessoires optionnels / optional accessories

111 BGI-BGCD bandeja / plateau / tray

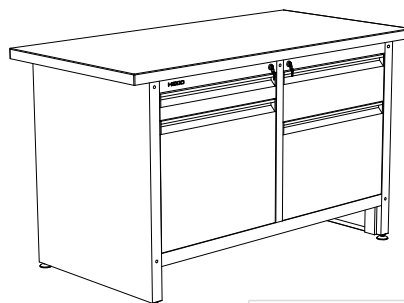

		L x A x H
111 15 07	132 Kg	1500x750x895
111 15 07 C	125 Kg	1500x750x895

accesorios / accessoires / accessories

111 C 100	cajón / tiroir /drawer		
111 PM I	puerta / porte / door		
111 C 200	cajón / tiroir /drawer		
111 PP D	puerta / porte / door		

accesorios opcionales / accessoires optionnels / optional accessories

111 BGI-BGCD bandeja / plateau / tray

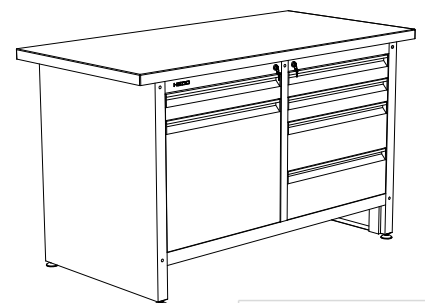

		L x A x H
111 15 08	153 Kg	1500x750x895
111 15 08 C	146 Kg	1500x750x895

accesorios / accessoires / accessories

111 C 100	cajón / tiroir /drawer		
111 PM I	puerta / porte / door		
3x 111 C 100	cajones / tiroirs /drawers		
2x 111 C 200	cajones / tiroirs /drawers		

accesorios opcionales / accessoires optionnels / optional accessories

111 BGCD bandeja / plateau / tray

SERIE 111 20 STANDARD



Carga total repartida.
Charge totale répartie.
Total distributed load.

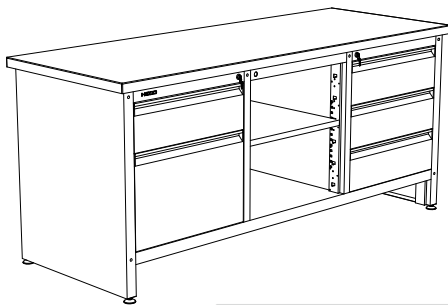

L x A x H		
111 20 01	177 Kg	2000x750x895
111 20 01 C	168 Kg	2000x750x895

accesorios / accessoires / accessories

111 C 200	cajón / tiroir / drawer		
111 PP I	puerta / porte / door		
111 BGCD	estanteria / étagère / shelf		
3x 111 C 200	cajones / tiroirs / drawers		

accesorios opcionales / accessoires optionnels / optional accessories

111 BGI bandeja / plateau / tray

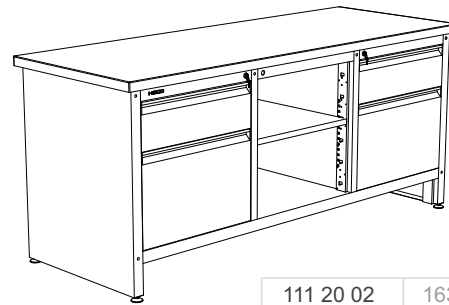

L x A x H		
111 20 02	163 Kg	2000x750x895
111 20 02 C	154 Kg	2000x750x895

accesorios / accessoires / accessories

111 C 200	cajón / tiroir / drawer		
111 PP I	puerta / porte / door		
111 BGCD	estanteria / étagère / shelf		
111 C 200	cajón / tiroir / drawer		
111 PP D	puerta / porte / door		

accesorios opcionales / accessoires optionnels / optional accessories

111 BGI-BGCD bandeja / plateau / tray



L x A x H		
111 20 03	154 Kg	2000x750x895
111 20 03 C	145 Kg	2000x750x895

accesorios / accessoires / accessories

111 C 200	cajón / tiroir / drawer		
111 PP I	puerta / porte / door		
111 BGCD	estanteria / étagère / shelf		
111 PG D	puerta / porte / door		

accesorios opcionales / accessoires optionnels / optional accessories

111 BGI-BGCD bandeja / plateau / tray

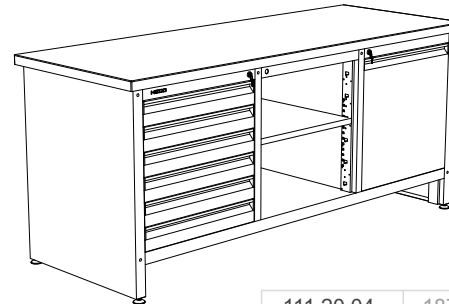

L x A x H		
111 20 04	187 Kg	2000x750x895
111 20 04 C	178 Kg	2000x750x895

accesorios / accessoires / accessories

6x 111 C 100	cajones / tiroirs / drawers		
111 BGCD	estanteria / étagère / shelf		
111 PG D	puerta / porte / door		

accesorios opcionales / accessoires optionnels / optional accessories

111 BGCD bandeja / plateau / tray

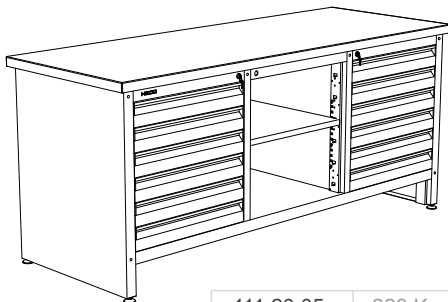

L x A x H		
111 20 05	228 Kg	2000x750x895
111 20 05 C	219 Kg	2000x750x895

accesorios / accessoires / accessories

6x 111 C 100	cajones / tiroirs / drawers		
111 BGCD	estanteria / étagère / shelf		
6x 111 C 100	cajones / tiroirs / drawers		

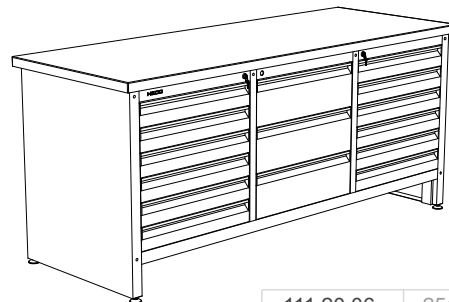

L x A x H		
111 20 06	251 Kg	2000x750x895
111 20 06 C	242 Kg	2000x750x895

accesorios / accessoires / accessories

6x 111 C 100	cajones / tiroirs / drawers		
3x 111 C 200	cajones / tiroirs / drawers		
6x 111 C 100	cajones / tiroirs / drawers		

SERIE 111 20 STANDARD



1000

Carga total repartida.
Charge totale répartie.
Total distributed load.

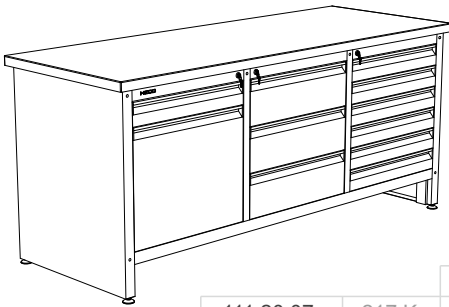

L x A x H		
111 20 07	217 Kg	2000x750x895
111 20 07 C	208 Kg	2000x750x895

accesorios / accessoires / accessories

111 C 100 cajón / tiroir / drawer

111 PM I puerta / porte / door

3x 111 C 200 cajones / tiroirs / drawers

6x 111 C 100 cajones / tiroirs / drawers

accesorios opcionales / accessoires optionnels / optional accessories

111 BG I bandeja / plateau / tray

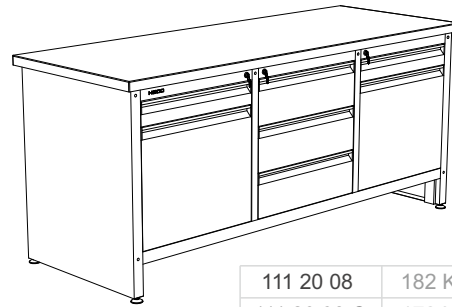

L x A x H		
111 20 08	182 Kg	2000x750x895
111 20 08 C	173 Kg	2000x750x895

accesorios / accessoires / accessories

111 C 100 cajón / tiroir / drawer

111 PM I puerta / porte / door

3x 111 C 200 cajones / tiroirs / drawers

111 C 100 cajones / tiroirs / drawers

111 PM D puerta / porte / door

accesorios opcionales / accessoires optionnels / optional accessories

111 BGI-BGCD bandeja / plateau / tray

SERIE 111 COMPONENTES COMPOSANTS / COMPONENTS

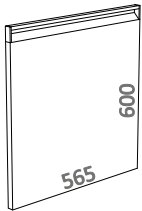

SERIE 111 PG D
SERIE 111 PG I
4,4 kg

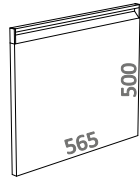

SERIE 111 PM D
SERIE 111 PM I
3,6 kg

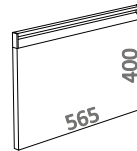

SERIE 111 PP D
SERIE 111 PP I
3,1 kg

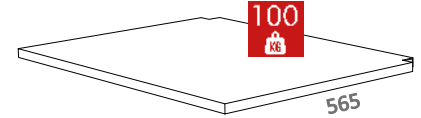

SERIE 111 BGCD
4 kg

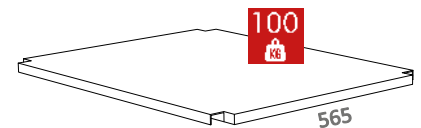

SERIE 111 BGI
3 kg

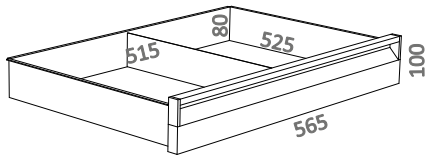

100 KG
SERIE 111 C 100
7,5 kg

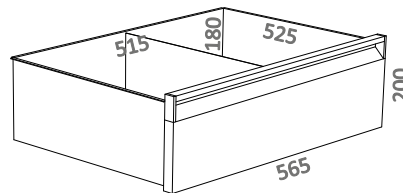

100 KG
SERIE 111 C 200
9 kg

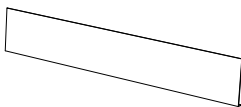

SERIE 111 D 100
División galvanizada
Division galvanisée
Galvanized division

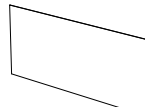

SERIE 111 D 200
División galvanizada
Division galvanisée
Galvanized division

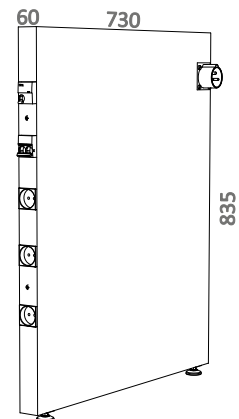

SERIE 111 PE

Toma de corriente+3 bases+magnetotérmico+diferencial
Prise + 3 bases + magnéto thermique + différentiel
Plug + 3 bases + thermal magneto + differential

SERIE 112 ref. 112 / 112 PG / 112 R

Banco de trabajo con patas fijas, graduables o ruedas.
Établis avec pieds fixes, pieds réglables ou roues.
Modular workbench with fixed or adjustable legs, or wheels.



Tornillos enrasados.
Vis affleurantes.
Flush screws.



SERIE 112 R

SERIE 112 PG

SERIE 112

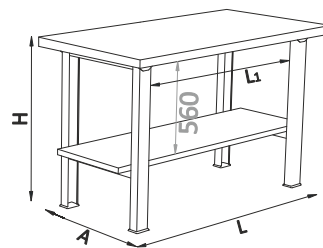

		L x A x H (mm)	L1
112 10	48 Kg	1000x750x880	1617
112 13	58 Kg	1300x750x880	1507
112 15	66 Kg	1500x750x880	1177
112 18	76 Kg	1800x750x880	957
112 20	83 Kg	2000x750x880	627

e 2 mm

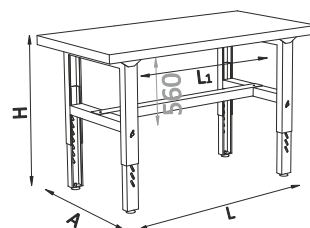

		L x A x H (mm)	L1
112 10 PG	48 Kg	1000x750x860-1110	1617
112 13 PG	58 Kg	1300x750x860-1110	1507
112 15 PG	66 Kg	1500x750x860-1110	1177
112 18 PG	76 Kg	1800x750x860-1110	957
112 20 PG	83 Kg	2000x750x860-1110	627

e 2 mm

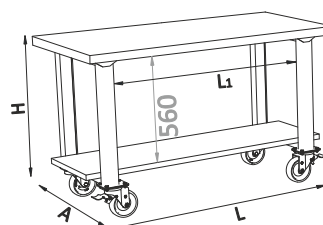

		L x A x H (mm)	L1
112 10 R	60 Kg	1000x750x880	1617
112 13 R	70 Kg	1300x750x880	1507
112 15 R	78 Kg	1500x750x880	1177
112 18 R	88 Kg	1800x750x880	957
112 20 R	95 Kg	2000x750x880	627

e 2 mm

Cajones disponibles.
Tiroirs disponibles.
Available drawers.



129 / 132 / 133 / 113 / 153

OPCIONAL OPTION OPTION



e 50 mm

KG Carga total repartida.
Charge totale répartie.
Total distributed load.
1000

i Montaje con tornillos (se entrega desmontado).
Montage avec vis (livraison démonté).
Screw assembly (supplied disassembled).

i OPCIONAL: Entrega montado ver tarifa.
OPTIONNEL: Livraison assemblée voir tarif.
OPTIONAL: Assembled delivery see tariff.

e Para más información sobre accesorios. Ver. PAG 287.
Pour plus d'information au sujet des accessoires. Voir. PAGE 287.
For more information about accessories. See. PAGE 287.



Carga total repartida.
Charge totale répartie.
Total distributed load.

1000

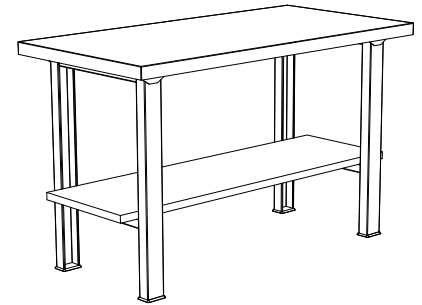
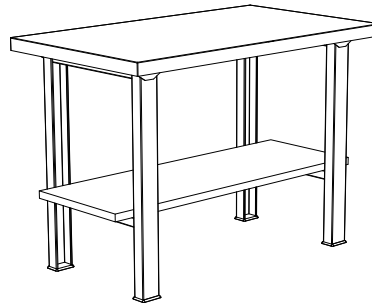
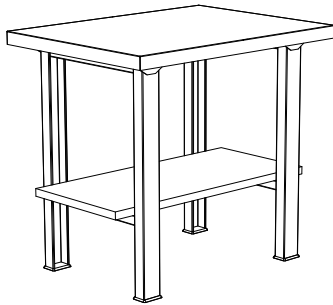

		LxAxH
112 10	48 Kg	1000x750x880
112 10 D	56 Kg	1000x750x880
112 10 M	51 Kg	1000x750x880

servicio / service / service	
112 M 10	montaje / assemblage / set up

		LxAxH
112 13	58 Kg	1300x750x880
112 13 D	64 Kg	1300x750x880
112 13 M	60 Kg	1300x750x880

servicio / service / service	
112 M 13	montaje / assemblage / set up

		LxAxH
112 15	66 Kg	1500x750x880
112 15 D	71 Kg	1500x750x880
112 15 M	68 Kg	1500x750x880

servicio / service / service	
112 M 15	montaje / assemblage / set up

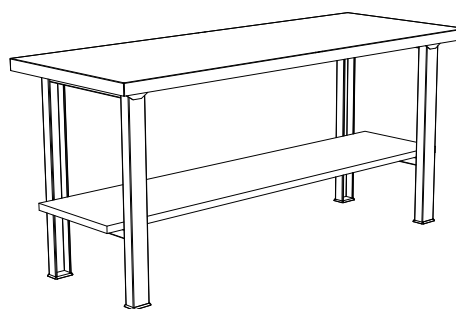
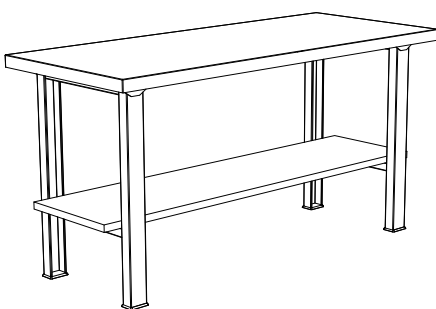

		LxAxH
112 18	76 Kg	1800x750x880
112 18 D	82 Kg	1800x750x880
112 18 M	77 Kg	1800x750x880

servicio / service / service	
112 M 18	montaje / assemblage / set up

		LxAxH
112 20	83 Kg	2000x750x880
112 20 D	92 Kg	2000x750x880
112 20 M	83 Kg	2000x750x880

servicio / service / service	
112 M 20	montaje / assemblage / set up

SERIE 145 18

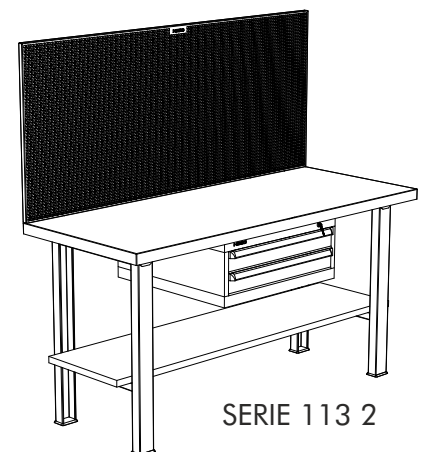

SERIE 113 2

SERIE 112 18

Solución Solution Solution

SERIE 112 PG STANDARD



Carga total repartida.
 Charge totale répartie.
 Total distributed load.

1000

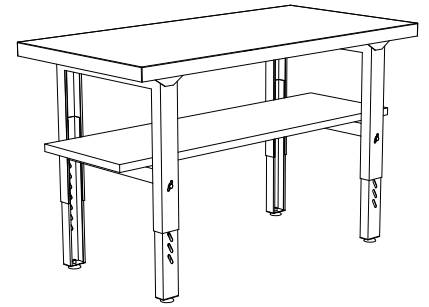
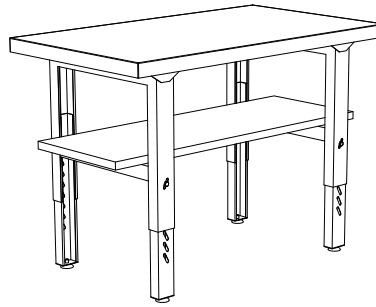
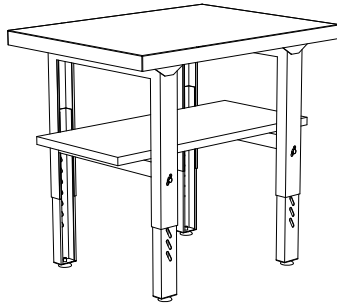

		LxAxH
112 10 PG	48 Kg	1000x750x860-1110
112 10 D PG	56 Kg	1000x750x880-1110
112 10 M PG	51 Kg	1000x750x860-1110

servicio / service / service	
112 M 10	montaje / assemblage / set up

		LxAxH
112 13 PG	58 Kg	1300x750x860-1110
112 13 D PG	64 Kg	1300x750x860-1110
112 13 M PG	60 Kg	1300x750x860-1110

servicio / service / service	
112 M 13	montaje / assemblage / set up

		LxAxH
112 15 PG	66 Kg	1500x750x860-1110
112 15 D PG	71 Kg	1500x750x860-1110
112 15 M PG	68 Kg	1500x750x860-1110

servicio / service / service	
112 M 15	montaje / assemblage / set up

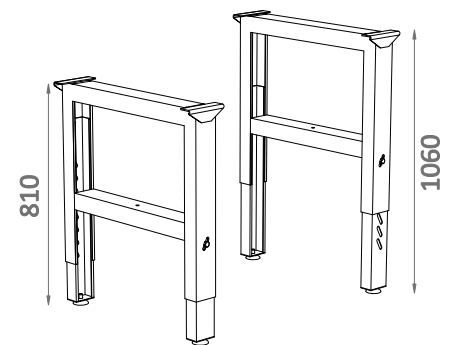
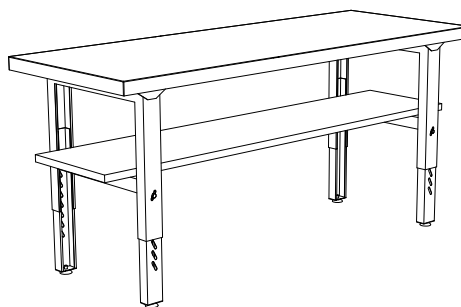
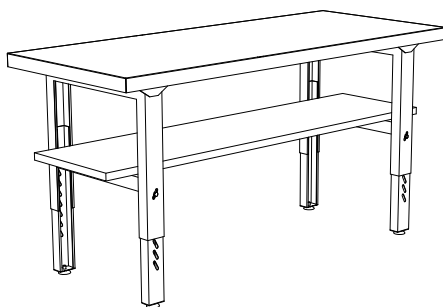

Solución Solution Solution

		LxAxH
112 18 PG	76 Kg	1800x750x860-1110
112 18 D PG	82 Kg	1800x750x860-1110
112 18 M PG	77 Kg	1800x750x860-1110

servicio / service / service	
112 M 18	montaje / assemblage / set up

		LxAxH
112 20 PG	83 Kg	2000x750x860-1110
112 20 D PG	92 Kg	2000x750x860-1110
112 20 M PG	83 Kg	2000x750x860-1110

servicio / service / service	
112 M 20	montaje / assemblage / set up

PIES PIEDS STANDS

Base redonda regulable en altura.
 Base ronde réglable en hauteur.
 Height-adjustable round base.





Carga total repartida.
Charge totale répartie.
Total distributed load.

1000

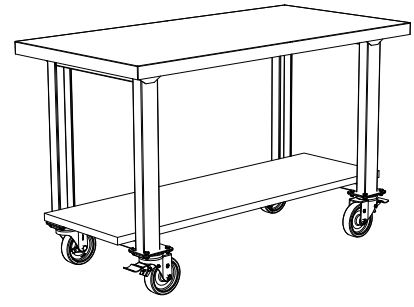
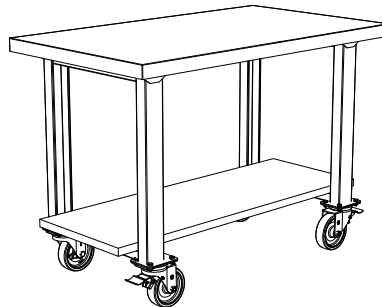
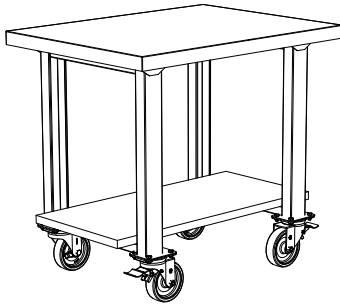

		L x A x H
112 10 R	60 Kg	1000x750x880
112 10 DR	67 Kg	1000x750x880
112 10 MR	63 Kg	1000x750x880

servicio / service / service

112 M 10 montaje / assemblage / set up

		L x A x H
112 13 R	70 Kg	1300x750x880
112 13 DR	76 Kg	1300x750x880
112 13 MR	72 Kg	1300x750x880

servicio / service / service

112 M 13 montaje / assemblage / set up

		L x A x H
112 15 R	78 Kg	1500x750x880
112 15 DR	83 Kg	1500x750x880
112 15 MR	80 Kg	1500x750x880

servicio / service / service

112 M 15 montaje / assemblage / set up

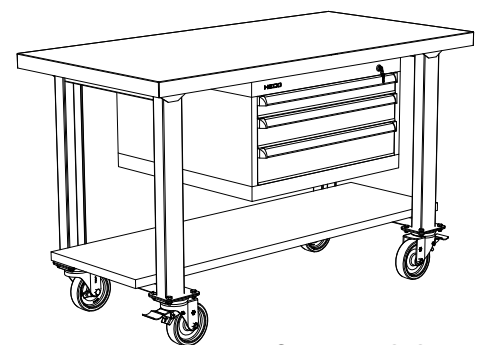
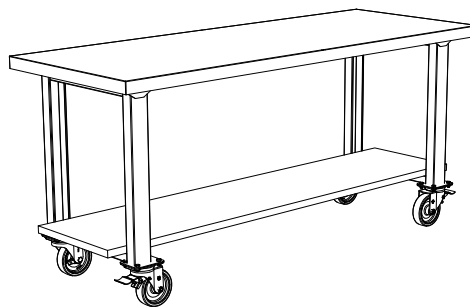
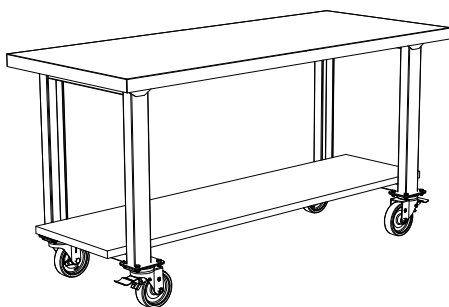

SERIE 112 15 MR

SERIE 113 3

Solución Solution Solution

		L x A x H
112 18 R	88 Kg	1800x750x880
112 18 DR	94 Kg	1800x750x880
112 18 MR	89 Kg	1800x750x880

servicio / service / service

112 M 18 montaje / assemblage / set up

		L x A x H
112 20 R	95 Kg	2000x750x880
112 20 DR	104 Kg	2000x750x880
112 20 MR	95 Kg	2000x750x880

servicio / service / service

112 M 20 montaje / assemblage / set up

RUEDAS ROUES WHEELS

Giratorias (2 con freno), recubrimiento poliuretano.
Pivotantes (2 avec frein), recouvrement polyuréthane.
Swivel (2 with brake), polyuretane covering.



Ø150mm
H188mm

SERIE 112 COMPONENTES COMPOSANTS / COMPONENTS

112 EC
112 EDM
112 EM

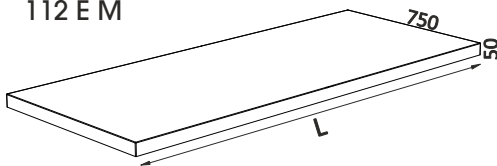

		L (mm)
112 EC 10	20,1 Kg	1000
112 EC 13	26,3 Kg	1300
112 EC 15	30,75 Kg	1500
112 EC 18	36,2 Kg	1800
112 EC 20	41,1 Kg	2000

* Chapa tôle / metal

i Se sirve con tornillos.
Vis inclus.
Included screws.

112 PE
Pata eléctrica.
Pied électrique.
Electric leg.

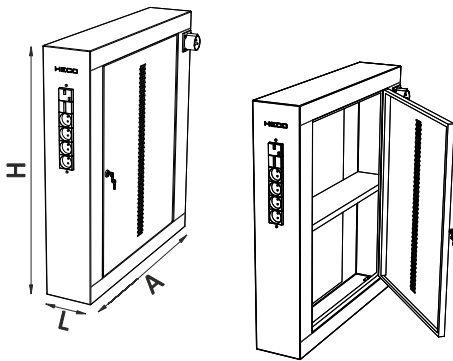

		L x A x H (mm)
112 PE	24 Kg	162x736x830

i Se sirve con tornillos i pies 112 BR.
Vis inclus et pieds 112 BR.
Included screws and 112 BR feet.

112 PR
Una unidad.
Une unité.
A unit.

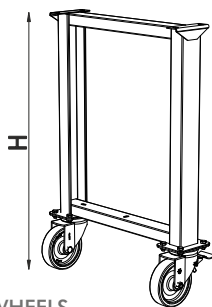

RUEDAS ROUES WHEELS

Recubrimiento poliuretano.
Recouvrement polyuréthane.
Polyuretane covering.

Ø= 150 mm
H= 188 mm



		H (mm)
112 PR	13,55 Kg	830

		L (mm)
112 E DM 10	25,1 Kg	1000
112 E DM 13	30,65 Kg	1300
112 E DM 15	37,4 Kg	1500
112 E DM 18	44,9 Kg	1800
112 E DM 20	49,8 Kg	2000

* DM MDF / MDF

		L (mm)
112 E M 10	22,3 Kg	1000
112 E M 13	28,6 Kg	1300
112 E M 15	33,2 Kg	1500
112 E M 18	39,6 Kg	1800
112 E M 20	44 Kg	2000

* Madera bois / wood

i Se sirve con tornillos.
Vis inclus.
Included screws.

112 RP

Barra de refuerzo.
Barre de renfort.
Reinforcementl.

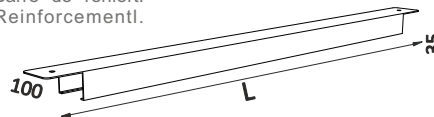

		L (mm)
112 RP 10	3 Kg	787
112 RP 13	3,7 Kg	1117
112 RP 15	4,2 Kg	1337
112 RP 18	5,3 Kg	1667
112 RP 20	5,6 Kg	1777

i Se sirve con tornillos.
Vis inclus.
Included screws.

112 CT

Cajón para teclado.
Tiroir pour clavier.
Keypad drawer.

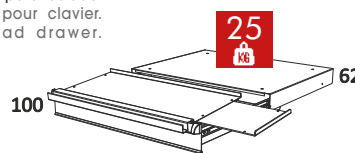

		LxAxH (mm)
112 CT	11 Kg	649x540x100

112 PG

Un juego de dos unidades.
Un jeu (2 unités).
One set of two units.

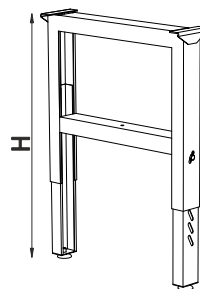

PIES PIEDS STANDS

Incluyen base redonda regulable en altura.
Base ronde réglable en hauteur inclus.
Height-adjustable round base included.



		H (mm)
112 PG	21,70 Kg	810-1060

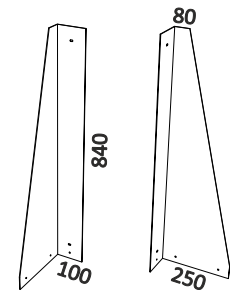

145 CTP

Un juego de dos unidades.
Un jeu (2 unités).
One set of two units.

		L x A x H
145 CTP	10 Kg	250 x 100 x 840

112 SL

Soporte luminária.
Support d'éclairage.
Lighting support.

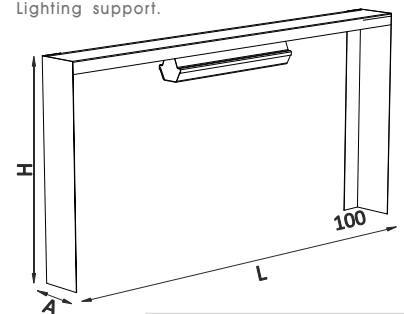

	W	L x A x H
112 10 SL	1x18	1000 x 200 x 1200
112 13 SL	1x18	1300 x 200 x 1200
112 15 SL	1x36	1500 x 200 x 1200
112 18 SL	1x58	1800 x 200 x 1200
112 20 SL	1x58	2000 x 200 x 1200

112 B

Bandeja inferior.
Plateau inférieur.
Bottom tray.

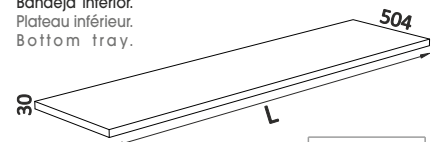

		L (mm)
112 B 10	9,5 Kg	1000
112 B 13	12,5 Kg	1300
112 B 15	14,75 Kg	1500
112 B 18	17,6 Kg	1800
112 B 20	19,3 Kg	2000

i Se sirve con tornillos.
Vis inclus.
Included screws.

112 P

Una unidad.
Une unité.
A unit.

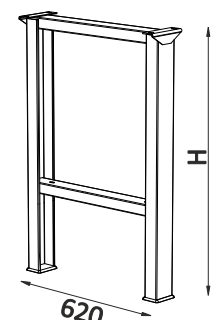

		H (mm)
112 P	8,05 Kg	830

Banco de trabajo con sistema hidráulico o motorización eléctrica.
Établi avec système hydraulique ou motorisation électrique.
Workbench with hydraulic system or electric motorization.

Sistema hidráulico / eléctrico.
Système hydraulique / électrique.
Hydraulic system / system.



PM
S H min. 712 mm.
H max. 1012 mm.

PM
A H min. 880 mm.
H max. 1180 mm.



PM: Panel de control.
PM: Panneau de contrôle.
PM: Control panel.

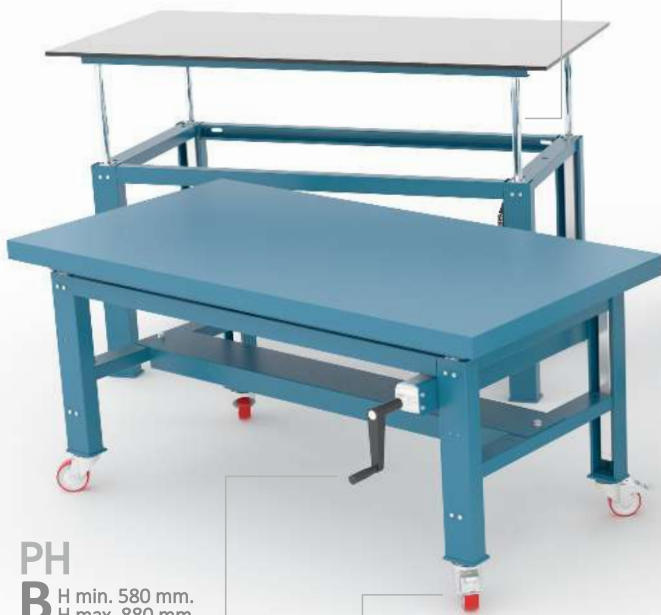

PH
B H min. 580 mm.
H max. 880 mm.

PH
S H min. 750 mm.
H max. 1050 mm.



PH: Manivela.
PH: Manivelle.
PH: Crank handle.

OPCIÓN: Ruedas.
OPTION: Roues.
OPTION: Wheels.

ENCIMERA PLAN DE TRAVAIL WORKTOP

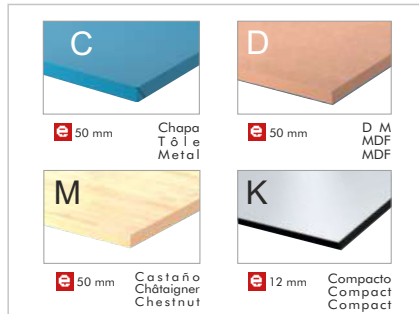

A H min. 880 mm.
H max. 1180 mm.

	L x A (mm)	H (mm) C/D/M	H (mm) K	L ₁ (mm) PH	L ₁ (mm) PM
112 PH/PM 10	1000x750	880 - 1180	842 - 1142	815	865
112 PH/PM 13	1300x750	880 - 1180	842 - 1142	1115	1165
112 PH/PM 15	1500x750	880 - 1180	842 - 1142	1315	1365
112 PH/PM 18	1800x750	880 - 1180	842 - 1142	1615	1665
112 PH/PM 20	2000x750	880 - 1180	842 - 1142	1815	1865

S H min. 750 mm.
H max. 1050 mm.

	L x A (mm)	H (mm) C/D/M	H (mm) K	L ₁ (mm) PH	L ₁ (mm) PM
112 PH/PM 10	1000x750	750 - 1050	712 - 1042	815	865
112 PH/PM 13	1300x750	750 - 1050	712 - 1042	1115	1165
112 PH/PM 15	1500x750	750 - 1050	712 - 1042	1315	1365
112 PH/PM 18	1800x750	750 - 1050	712 - 1042	1615	1665
112 PH/PM 20	2000x750	750 - 1050	712 - 1042	1815	1865

B H min. 580 mm.
H max. 880 mm.

	L x A (mm)	H (mm) C/D/M	H (mm) K	L ₁ (mm) PH	L ₁ (mm) PM
112 PH/PM 10	1000x750	580 - 880	542 - 842	815	865
112 PH/PM 13	1300x750	580 - 880	542 - 842	1115	1165
112 PH/PM 15	1500x750	580 - 880	542 - 842	1315	1365
112 PH/PM 18	1800x750	580 - 880	542 - 842	1615	1665
112 PH/PM 20	2000x750	580 - 880	542 - 842	1815	1865



Se entrega montado.
Livraison monté.
Supplied assembled.



Recorrido de 300 mm.
300 mm de course.
300 mm path.

e 2 mm Estructura chasis / frame

SERIE 112 PH STANDARD



600

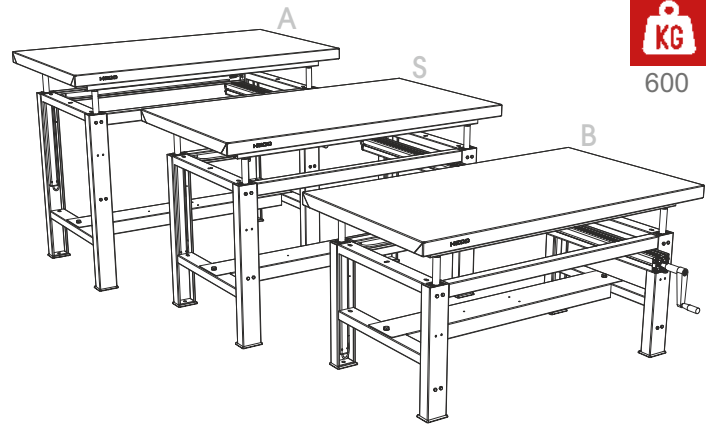
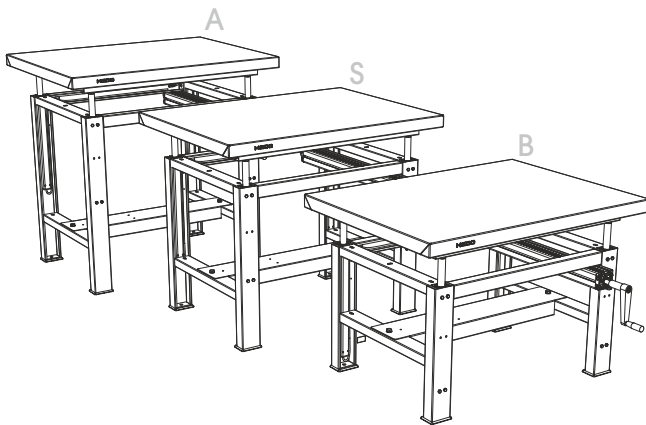

	C Kg	D Kg	M Kg	K Kg	LxAxH (C-D-M)(K)
112 10 C PH 30 B	39,55	43,42	41,25	30,96	1000x750x(580-880(-38))
112 10 C PH 30 S	50,91	55,91	53,11	39,79	1000x750x(750-1050(-38))
112 10 C PH 30 A	59,57	65,43	62,15	46,55	1000x750x(880-1180(-38))

	C Kg	D Kg	M Kg	K Kg	LxAxH (C-D-M)(K)
112 13 C PH 30 B	50,16	53,60	51,93	38,87	1300x750x(580-880(-38))
112 13 C PH 30 S	64,63	69,09	66,93	50,03	1300x750x(750-1050(-38))
112 13 C PH 30 A	75,66	80,89	78,36	58,53	1300x750x(880-1180(-38))

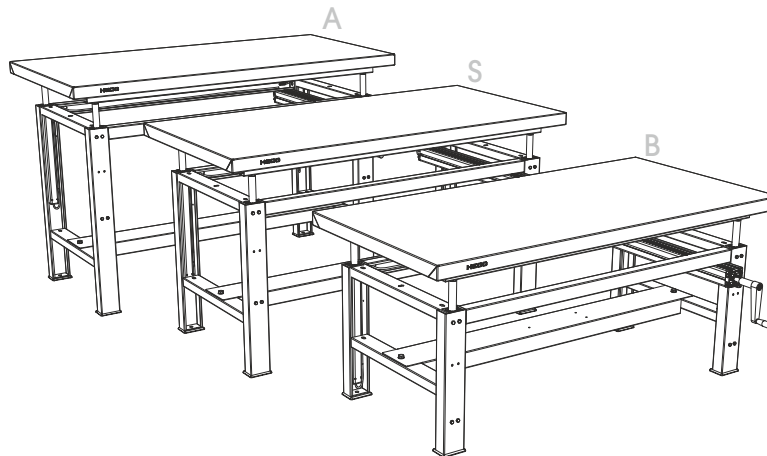

	C Kg	D Kg	M Kg	K Kg	LxAxH (C-D-M)(K)
112 15 C PH 30 B	57,60	62,74	59,49	44,26	1500x750x(580-880(-38))
112 15 C PH 30 S	74,26	80,91	76,71	57,01	1500x750x(750-1050(-38))
112 15 C PH 30 A	86,96	94,76	88,96	66,72	1500x750x(880-1180(-38))

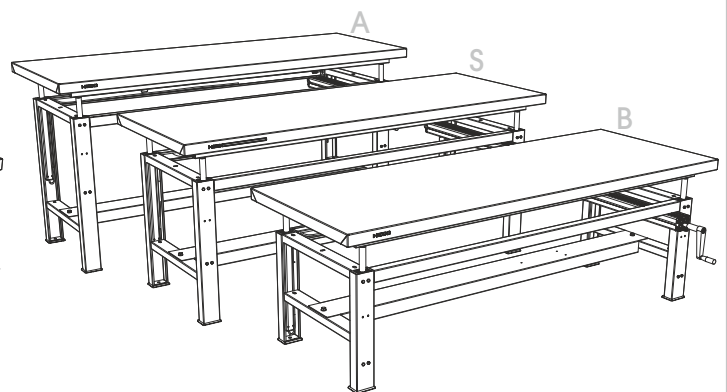
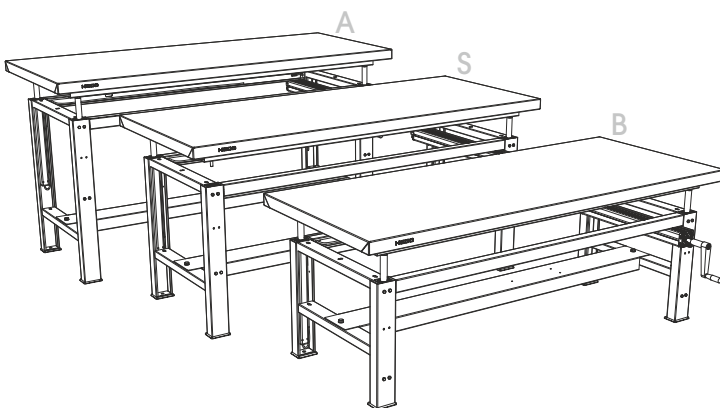

	C Kg	D Kg	M Kg	K Kg	LxAxH (C-D-M)(K)
112 18 C PH 30 B	67,24	73,96	69,86	51,78	1800x750x(580-880(-38))
112 18 C PH 30 S	86,73	95,43	90,13	66,73	1800x750x(750-1050(-38))
112 18 C PH 30 A	101,58	111,79	105,57	78,12	1800x750x(880-1180(-38))

	C Kg	D Kg	M Kg	K Kg	LxAxH (C-D-M)(K)
112 20 C PH 30 B	75,03	81,76	77,27	57,18	2000x750x(580-880(-38))
112 20 C PH 30 S	96,81	105,51	99,71	73,71	2000x750x(750-1050(-38))
112 20 C PH 30 A	113,41	123,61	116,81	86,31	2000x750x(880-1180(-38))

SERIE 112 PM STANDARD



600

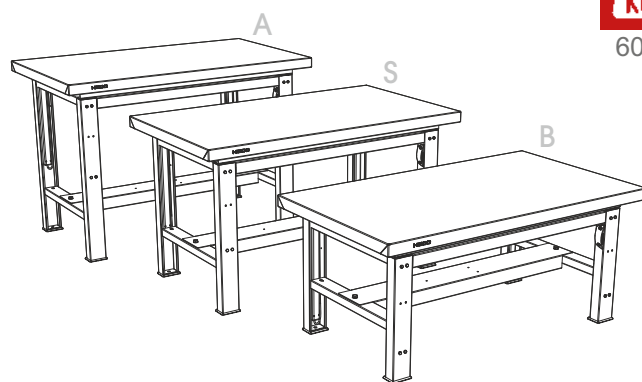
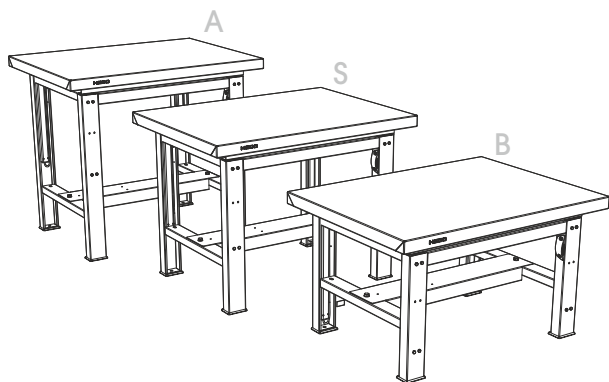

	C Kg	D Kg	M Kg	K Kg	L x A x H (C-D-M)(K)
112 10 C PM 30 B	38,68	42,55	40,38	30,09	1000x750x(580-880(-38))
112 10 C PM 30 S	50,04	55,04	52,24	38,92	1000x750x(750-1050(-38))
112 10 C PM 30 A	58,70	64,56	61,28	45,68	1000x750x(880-1180(-38))

	C Kg	D Kg	M Kg	K Kg	L x A x H (C-D-M)(K)
112 13 C PM 30 B	49,29	52,73	51,06	38,00	1300x750x(580-880(-38))
112 13 C PM 30 S	63,76	68,22	66,06	49,16	1300x750x(750-1050(-38))
112 13 C PM 30 A	74,79	80,02	77,49	57,66	1300x750x(880-1180(-38))

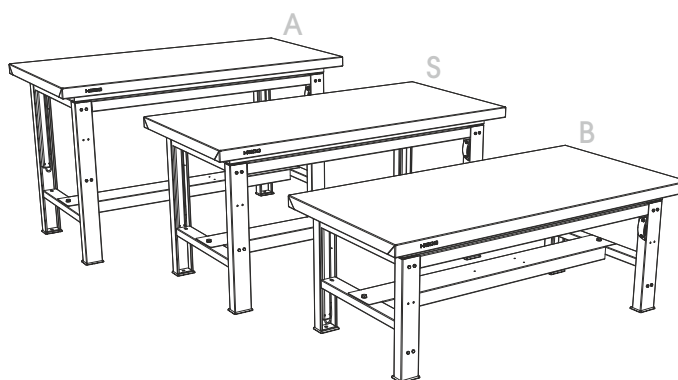

	C Kg	D Kg	M Kg	K Kg	L x A x H (C-D-M)(K)
112 15 C PM 30 B	56,73	61,87	58,62	43,39	1500x750x(580-880(-38))
112 15 C PM 30 S	73,39	80,04	75,84	56,14	1500x750x(750-1050(-38))
112 15 C PM 30 A	86,09	93,89	88,09	65,85	1500x750x(880-1180(-38))

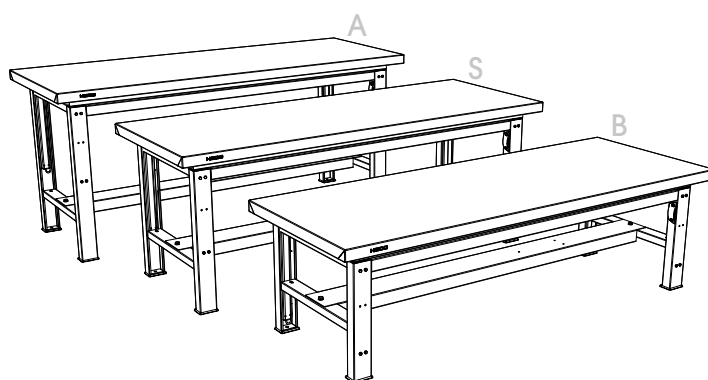
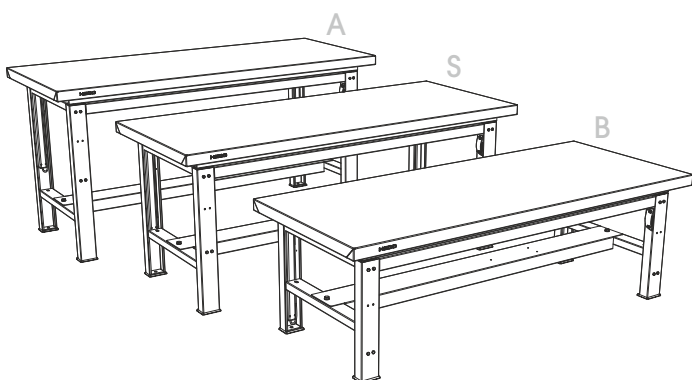

	C Kg	D Kg	M Kg	K Kg	L x A x H (C-D-M)(K)
112 18 C PM 30 B	66,37	73,09	68,99	50,91	1800x750x(580-880(-38))
112 18 C PM 30 S	85,86	94,56	89,26	65,86	1800x750x(750-1050(-38))
112 18 C PM 30 A	100,71	110,92	104,70	77,25	1800x750x(880-1180(-38))

	C Kg	D Kg	M Kg	K Kg	L x A x H (C-D-M)(K)
112 20 C PM 30 B	94,16	80,89	76,40	56,31	2000x750x(580-880(-38))
112 20 C PM 30 S	95,94	104,64	98,84	72,84	2000x750x(750-1050(-38))
112 20 C PM 30 A	112,54	122,74	115,94	85,44	2000x750x(880-1180(-38))

SERIE 118 ref. 118 / 118 P

Banco monobloque de alta resistencia.
Établis monobloc de haute résistance.
Monoblock workbench of high resistance.

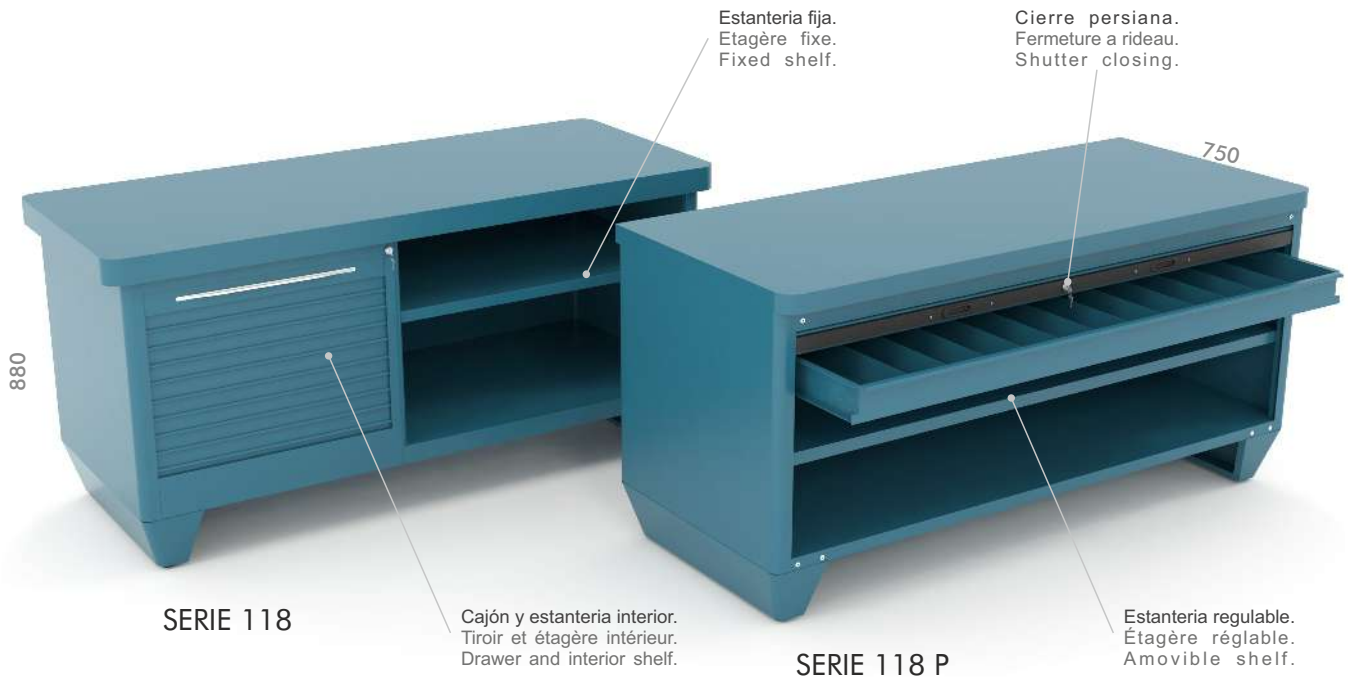

SERIE 118

Cajón y estantería interior.
Tiroir et étagère intérieur.
Drawer and interior shelf.

SERIE 118 P

Estanteria regulable.
Étagère réglable.
Adjustable shelf.

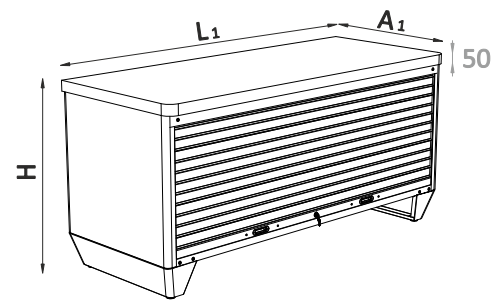
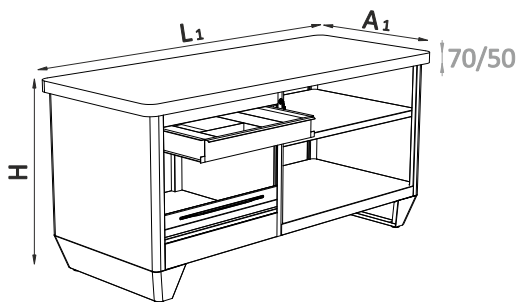

GS 100 Cajón.
Tiroir.
Drawer.

		H (mm)	L1 x A1 (mm)
118	142 Kg	880	1800x750
118 D	151 Kg	860	1800x750
118 M	144 Kg	860	1800x750

GS 100 Cajón.
Tiroir.
Drawer.

		H (mm)	L1 x A1 (mm)
118 10 P	89 Kg	880	1000x750
118 18 P	142 Kg	880	1800x750

OPCIONAL OPTION OPTION

		
Chapa Tôle Metal	D M MDF MDF	M Madera (castaño) Bois (châtaigner) Wood (chestnut)
e 70 mm	e 50 mm	e 50 mm

PIES PIEDS STANDS

Base redonda regulable en altura.
Base ronde réglable en hauteur.
Height-adjustable round base.



100 KG Carga total por cajón repartida.
Charge totale par tiroir répartie.
Distributed load for drawer.

i Estructura totalmente soldada.
Structure totalement soudée.
Welded structure.

i Cierre centralizado.
Fermeture centralisée.
Centralized closing.

e Para más información sobre accesorios. Ver. PAG. 286.
Pour plus d'information au sujet des accessoires. Voir. PAGE. 286.
For more information about accessories. See. PAGE. 286.

SERIE 118 STANDARD



Carga total repartida.
Charge totale répartie.
Total distributed load.

1000

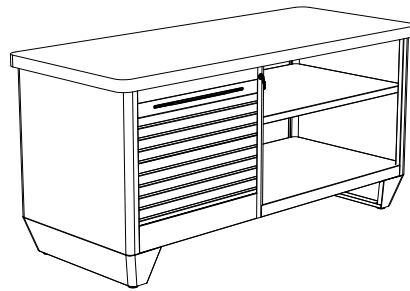
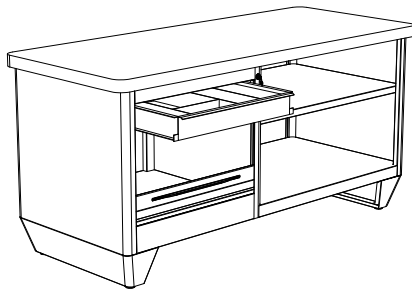

118 C

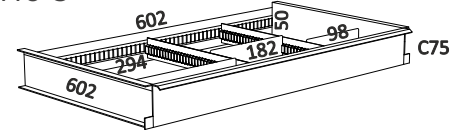

		L x A x H
118	142 Kg	1800x750x880
118 D	151 Kg	1800x750x880
118 M	144 Kg	1800x750x880

accesorios / accessoires / accessories		
118 C	cajón / tiroir / drawer	GS 100
* Máximo 3 cajones Maximum 3 tiroirs / Maximum 3 drawers		
Icon	L x A x H (mm)	VOL (m³)
1	1830x780x895	1,28

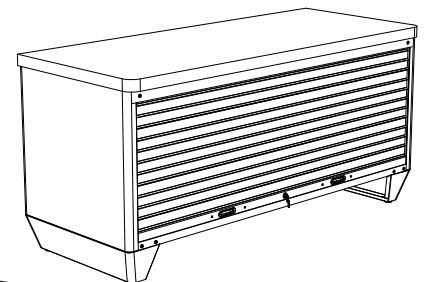
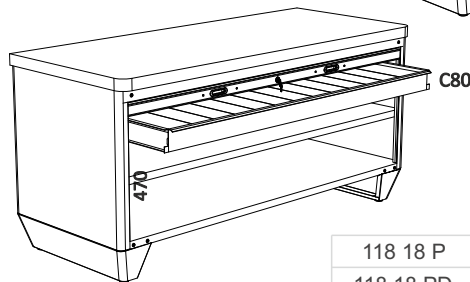
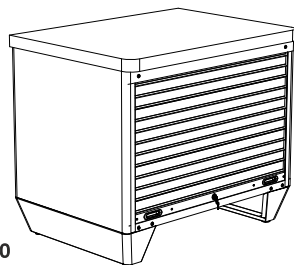
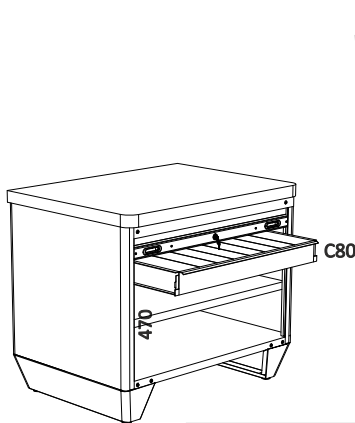

		L x A x H
118 10 P	89 Kg	1000x750x880
118 10 PD	94 Kg	1000x750x880
118 10 PM	91 Kg	1000x750x880

accesorios / accessoires / accessories		
118 10 C	cajón / tiroir / drawer	GS 100
* Máximo 3 cajones Maximum 3 tiroirs / Maximum 3 drawers		
Icon	L x A x H (mm)	VOL (m³)
1	1030x780x895	0,72

		L x A x H
118 18 P	142 Kg	1800x750x880
118 18 PD	151 Kg	1800x750x880
118 18 PM	144 Kg	1800x750x880

accesorios / accessoires / accessories		
118 18 C	cajón / tiroir / drawer	GS 100
* Máximo 3 cajones Maximum 3 tiroirs / Maximum 3 drawers		
Icon	L x A x H (mm)	VOL (m³)
1	1830x780x895	1,28

SERIE 118 COMPONENTES COMPOSANTS / COMPONENTS



Total de cajones admitidos 4 unidades por banco.
Total des tiroirs admis 4 unités par établi.
Total of drawers admitted 4 units per workbench.



Carga total por cajón repartida.
Charge totale par tiroir répartie.
Distributed load for drawer.

118 10 C

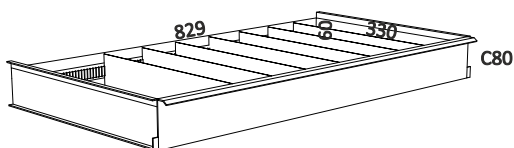

118 18 C

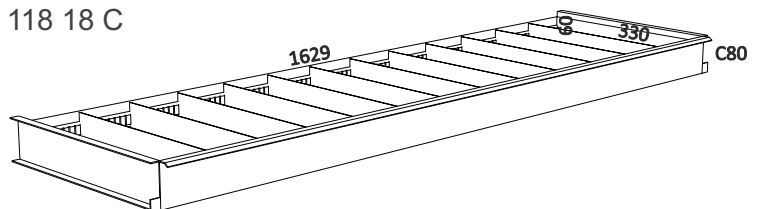

		L x A x H
118 10 C	GS 100	15 Kg 829x330x80

* 7 separaciones 7 séparations / 7 separations

		L x A x H
118 18 C	GS 100	20 Kg 1629x330x80

* 14 separaciones 14 séparations / 14 separations

SERIE 120 ref. 120 10 1 / 120 10 5

Banco plegable. Totalmente rígido gracias a su sistema de plegado.
Établis pliant. Absolument rigide grâce au système de pliage.
Folding workbench. Our folding system ensures complete rigidity.



300



SERIE 120 1

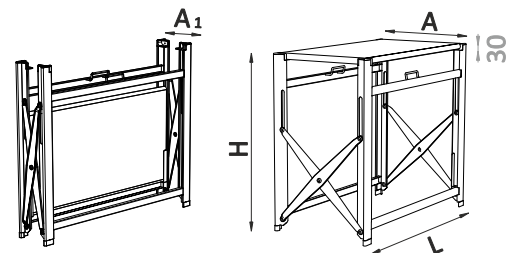

SERIE 120 5

OPCIONAL OPTION OPTION

Chapa galvanizada Tôle galvanisée Galvanized metal sheet	D M MDF MDF
e 40 mm	

		L x A x H (mm)	A1 (mm)
120 10 1	23,62 Kg	970x510x840	115
120 10 5	21,60 Kg	970x510x840	115

e 2 mm



Montaje con tornillos (se entrega desmontado).
Montage avec vis (livraison démonté).
Screw assembly (supplied disassembled).



Fácilmente transportable, registrado como modelo de utilidad 930 10 89.
Facilement transportable, enregistré comme modèle d'utilité 930 10 89.
Easy transport, registered like 930 10 89 utility model.

SERIE 120 STANDARD



300

Carga total repartida.
Charge totale répartie.
Total distributed load.

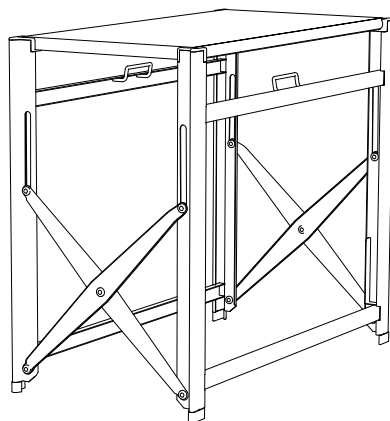

		L x A x H
120 10 1	23,62 Kg	970x510x840

* Encimera de DM Plan de travail MDF / MDF worktop

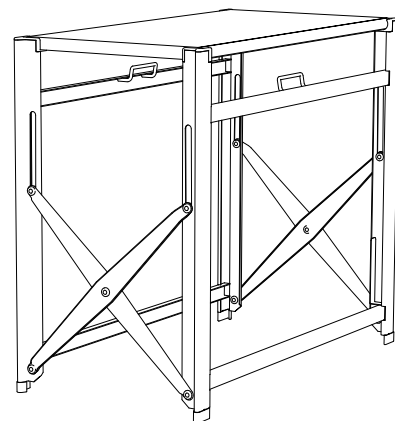

		L x A x H
120 10 5	21,60 Kg	970x510x840

* Encimera de chapa Plan de travail tôle / Metal worktop



Banco de trabajo con bandeja inferior en chapa galvanizada y graduable en altura.
Table de travail avec plateau inférieur en tôle galvanisée et réglable en hauteur.
Workbench with inferior galvanized steel tray and adjustable in height.

SERIE 121 5 R

SERIE 121 1



RUEDAS ROUES WHEELS

Ruedas de goma.
Roues en caoutchouc.
Rubber wheels.

Ø 100mm
H 135mm



OPCIONAL OPTION OPTION

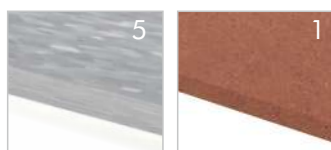

Chapa galvanizada
Tôle galvanisée
Galvanized metal sheet

D M
MDF
MDF

e 40 mm

ESTANTERIA ÉTAGÈRE SHELF



121 0 01



121 0 15

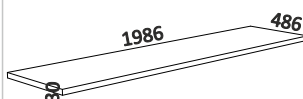

121 0 20

Accesorio permitido.
Accessoire permis.
Allowed accessory.

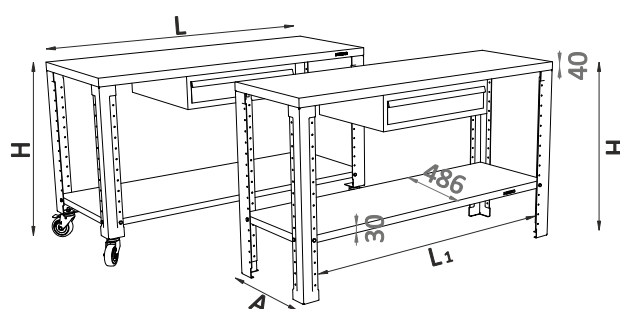

		L x A x H (mm)	L1 (mm)
121 10	30 Kg	1000x500x880	845
121 15	40 Kg	1500x500x880	1345
121 20	53 Kg	2000x500x880	1845
121 10 R	33 Kg	1000x500x1000	845
121 15 R	43 Kg	1500x500x1000	1345
121 20 R	56 Kg	2000x500x1000	1845

* Encimera de DM Plan de travail MDF / MDF worktop

CAJON TIROIR DRAWER

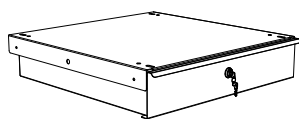

SERIE 132



Para más información sobre los cajones, ver PÁG 286.
Pour plus d'information sur les tiroirs, voir PAGE 286.
For further information on the drawers, see PAGE 286.



Montaje con tornillos (se entrega desmontado).
Montage avec vis (livraison démonté).
Screw assembly (supplied disassembled).

e 2 mm

SERIE 121 STANDARD



200

Carga total repartida.
Charge totale répartie.
Total distributed load.

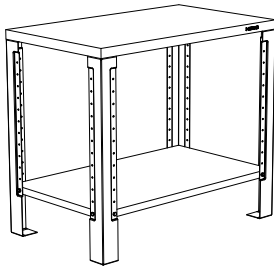

L x A x H		
121 10 1	30 Kg	1000x500x880
121 10 5	26 Kg	

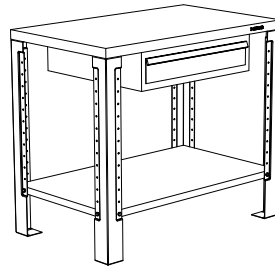

L x A x H		
121 10 1 1C	39 Kg	1000x500x880
121 10 5 1C	35 Kg	

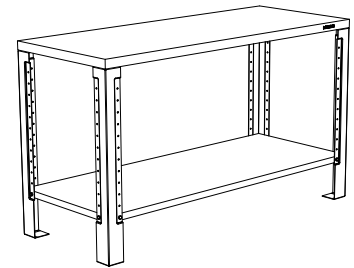

L x A x H		
121 15 1	40 Kg	1500x500x880
121 15 5	30 Kg	

accesorios / accessoires / accessories

132 cajón / tiroir / drawer

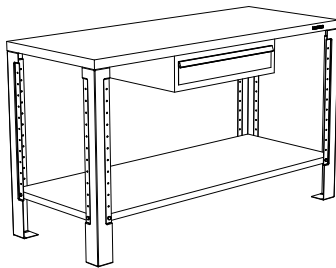

L x A x H		
121 15 1 1C	49 Kg	1500x500x880
121 15 5 1C	39 Kg	

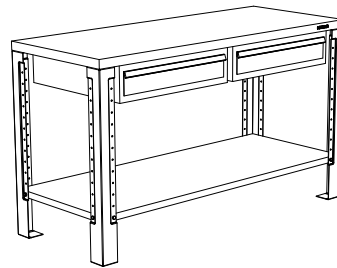

L x A x H		
121 15 1 2C	58 Kg	1500x500x880
121 15 5 2C	48 Kg	

accesorios / accessoires / accessories

2x 132 cajón / tiroir / drawer

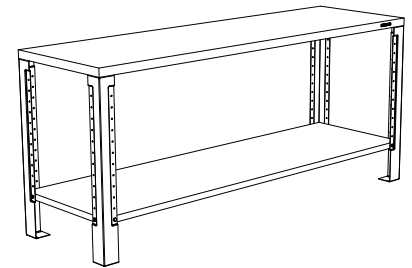

L x A x H		
121 20 1	53 Kg	2000x500x880
121 20 5	44 Kg	

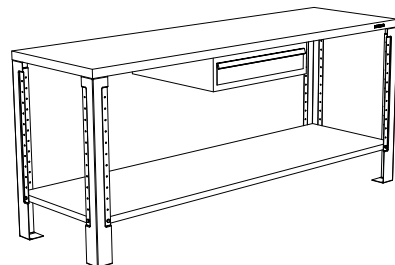

L x A x H		
121 20 1 1C	62 Kg	2000x500x880
121 20 5 1C	53 Kg	

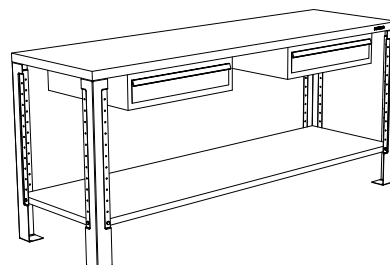

L x A x H		
121 20 1 2C	71 Kg	2000x500x880
121 20 5 2C	62 Kg	

accesorios / accessoires / accessories

2x 132 cajón / tiroir / drawer

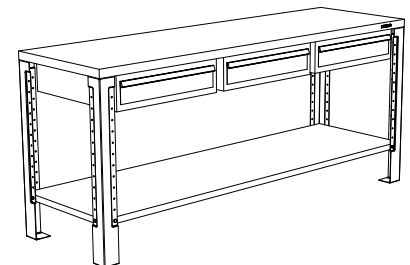

L x A x H		
121 20 1 3C	80 Kg	2000x500x880
121 20 5 3C	71 Kg	

accesorios / accessoires / accessories

3x 132 cajón / tiroir / drawer

SERIE 121 R STANDARD



180

Carga total repartida.
 Charge totale répartie.
 Total distributed load.

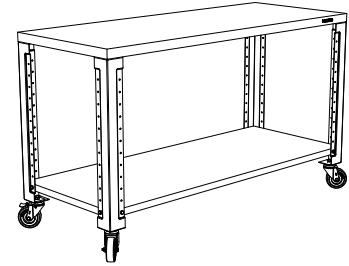
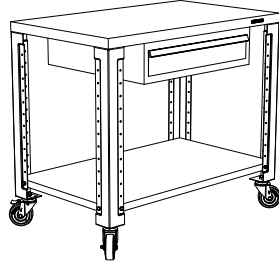
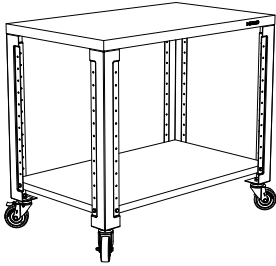

		LxAxH
121 10 1 R	33 Kg	1000x500x1000
121 10 5 R	29 Kg	

		LxAxH
121 10 1 R 1C	42 Kg	1000x500x1000
121 10 5 R 1C	38 Kg	

		LxAxH
121 15 1 R	43 Kg	1500x500x1000
121 15 5 R	33 Kg	

accesorios / accessoires / accessories	
132	cajón / tiroir / drawer

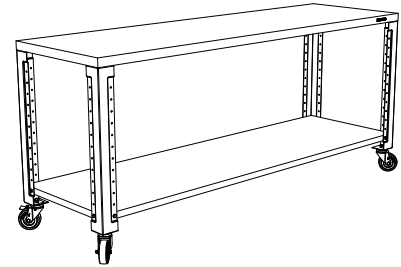
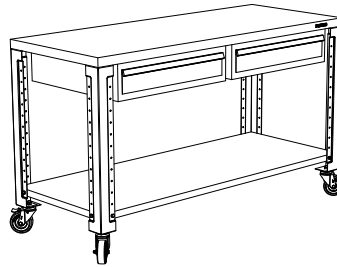
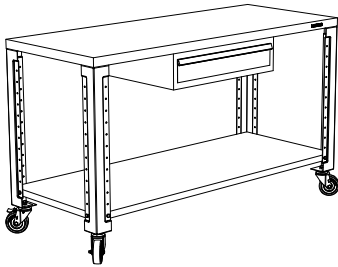

		LxAxH
121 15 1 R 1C	52 Kg	1500x500x1000
121 15 5 R 1C	42 Kg	

		LxAxH
121 15 1 R 2C	61 Kg	1500x500x1000
121 15 5 R 2C	51 Kg	

		LxAxH
121 20 1 R	56 Kg	2000x500x1000
121 20 5 R	47 Kg	

accesorios / accessoires / accessories	
132	cajón / tiroir / drawer

accesorios / accessoires / accessories	
2x 132	cajón / tiroir / drawer

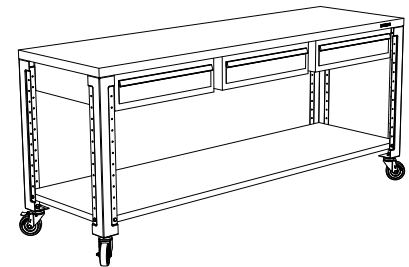
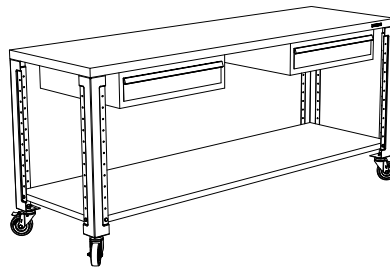
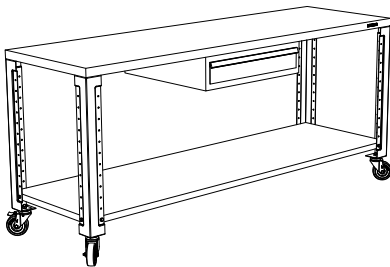

		LxAxH
121 20 1 R 1C	65 Kg	2000x500x1000
121 20 5 R 1C	56 Kg	

		LxAxH
121 20 1 R 2C	74 Kg	2000x500x1000
121 20 5 R 2C	65 Kg	

		LxAxH
121 20 1 R 3C	83 Kg	2000x500x1000
121 20 5 R 3C	74 Kg	

accesorios / accessoires / accessories	
132	cajón / tiroir / drawer

accesorios / accessoires / accessories	
2x 132	cajón / tiroir / drawer

accesorios / accessoires / accessories	
3x 132	cajón / tiroir / drawer

SERIE 136 ref. 136 15 / 136 18 / 136 20



Banco de trabajo configurable; armarios / cajones / patas.
Établis personnalisé; armoires / tiroirs / pieds.
Customizable workbench; cabinets / drawers / legs.



SERIE 136 20 22

SERIE 136 18 2

SERIE 136 15 1

CAJONES TIROIRS DRAWERS

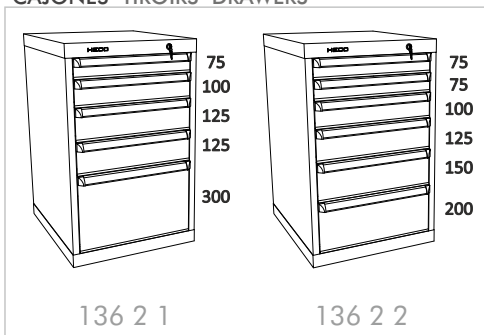

136 2 1

136 2 2

ARMARIO ARMOIRE CABINET

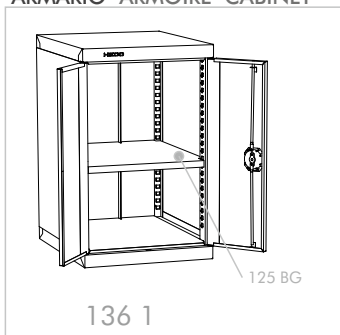

136 1

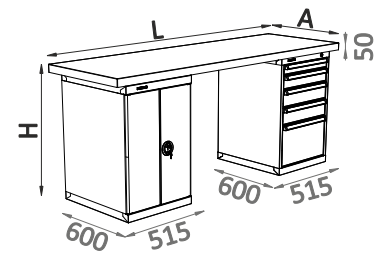

i Cada cajón se sirve con 1 división ranurada y 3 planas.
Chaque tiroir est servi avec 1 division rainuré et 3 intercalaires.
Each drawer is served with 1 slotted division and 3 simples.

OPCIONAL OPTION OPTION



Chapa
Tôle
Metal

D M
MDF
MDF

Madera (castaño)
Bois (châtaigner)
Wood (chestnut)

e 50 mm

		L x A x H (mm)
136 15	74-102 Kg	1500x750x880
136 18	83-163 Kg	1800x750x880
136 20	113-174 Kg	2000x750x880

e 2 mm

i Cierre centralizado.
Fermeture centralisée.
Centralized closing.



Para más información sobre los armarios ver PÁG. 38/61.
Pour plus d'information sur les armoires, voir PAGE 38/61.
For further information on the cabinets see PAGE 38/61.

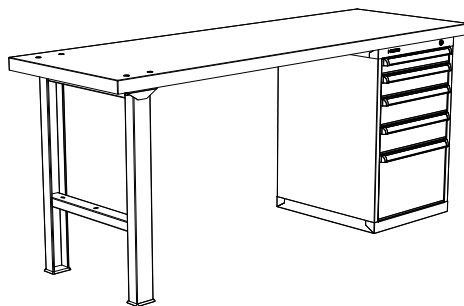
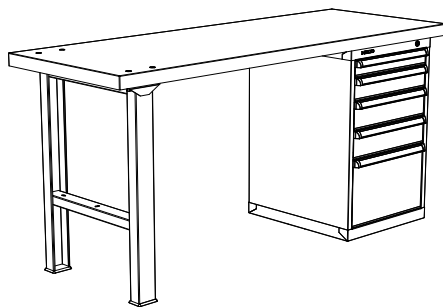
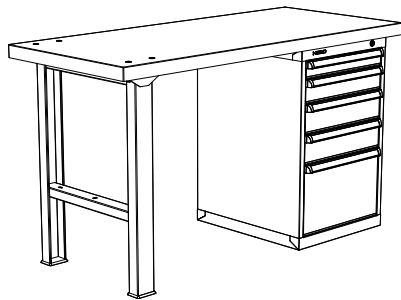

Se entrega montado.
Livraison monté.
Supplied assembled.

SERIE 136 STANDARD

1000
**Carga total repartida.
Charge totale répartie.
Total distributed load.**

		L x A x H
136 15 C 1	102 Kg	1500x750x880
136 15 D 1	110 Kg	
136 15 M 1	105 Kg	

accesorios / accessoires / accessories

136 2 1	cajones / tiroirs / drawers		
---------	-----------------------------	--	--

		L x A x H
136 18 C 1	111 Kg	1800x750x880
136 18 D 1	121 Kg	
136 18 M 1	111 Kg	

accesorios / accessoires / accessories

136 2 1	cajones / tiroirs / drawers		
---------	-----------------------------	--	--

		L x A x H
136 20 C 1	117 Kg	2000x750x880
136 20 D 1	129 Kg	
136 20 M 1	115 Kg	

accesorios / accessoires / accessories

136 2 1	cajones / tiroirs / drawers		
---------	-----------------------------	--	--

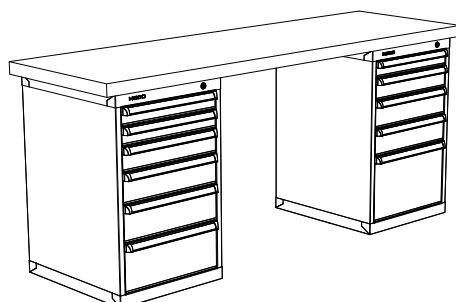
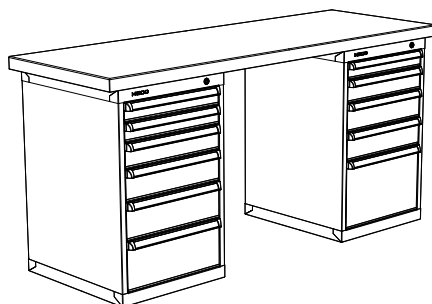
SERIE 136 STANDARD

1000
**Carga total repartida.
Charge totale répartie.
Total distributed load.**

		L x A x H
136 18 C 2	163 Kg	1800x750x880
136 18 D 2	172 Kg	
136 18 M 2	165 Kg	

accesorios / accessoires / accessories

136 2 1	cajones / tiroirs / drawers		
---------	-----------------------------	--	--

136 2 2	cajones / tiroirs / drawers		
---------	-----------------------------	--	--

		L x A x H
136 20 C 2	174 Kg	2000x750x880
136 20 D 2	186 Kg	
136 20 M 2	172 Kg	

accesorios / accessoires / accessories

136 2 1	cajones / tiroirs / drawers		
---------	-----------------------------	--	--

136 2 2	cajones / tiroirs / drawers		
---------	-----------------------------	--	--

SERIE 136 STANDARD



Carga total repartida.
Charge totale répartie.
Total distributed load.

1000

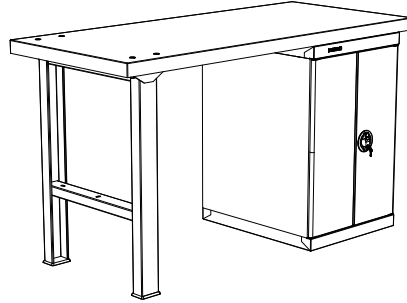

		L x A x H
136 15 C 11	74 Kg	1500x750x880
136 15 D 11	82 Kg	
136 15 M 11	77 Kg	

accesorios / accessoires / accessories

136 1 armario / armoire / cabinet

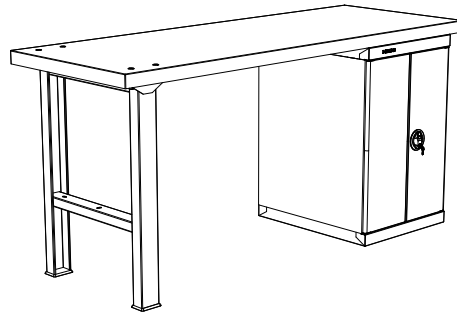

		L x A x H
136 18 C 11	83 Kg	1800x750x880
136 18 D 11	93 Kg	
136 18 M 11	83 Kg	

accesorios / accessoires / accessories

136 1 armario / armoire / cabinet

SERIE 136 STANDARD



Carga total repartida.
Charge totale répartie.
Total distributed load.

1000

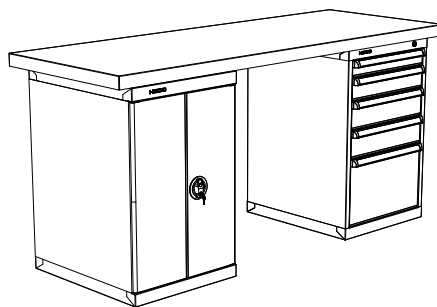

		L x A x H
136 18 C 21	135 Kg	1800x750x880
136 18 D 21	145 Kg	
136 18 M 21	135 Kg	

accesorios / accessoires / accessories

136 2 1 cajones / tiroirs / drawers

136 1 armario / armoire / cabinet

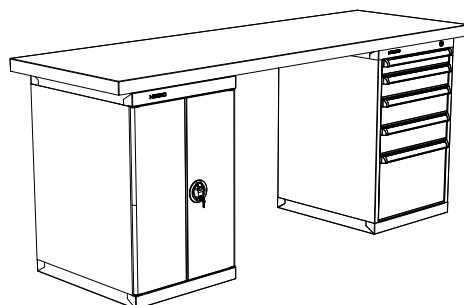

		L x A x H
136 20 C 21	141 Kg	2000x750x880
136 20 D 21	153 Kg	
136 20 M 21	139 Kg	

accesorios / accessoires / accessories

136 2 1 cajones / tiroirs / drawers

136 1 armario / armoire / cabinet

SERIE 136 STANDARD

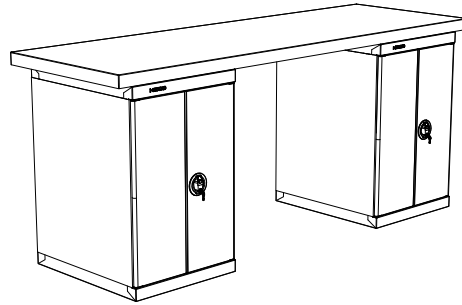
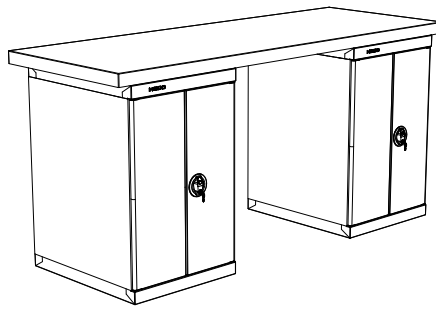

1000

Carga total repartida.
Charge totale répartie.
Total distributed load.

		L x A x H
136 18 C 22	107 Kg	1800x750x880
136 18 D 22	117 Kg	
136 18 M 22	107 Kg	

accesorios / accessoires / accessories	
2x 136 1	armario / armoire / cabinet

		L x A x H
136 20 C 22	113 Kg	2000x750x880
136 20 D 22	125 Kg	
136 20 M 22	111 Kg	

accesorios / accessoires / accessories	
2x 136 1	armario / armoire / cabinet

SERIE 137

Banco de trabajo con 3 encimeras.
Établis avec 3 plateaux.
Workbench with 3 worktops.

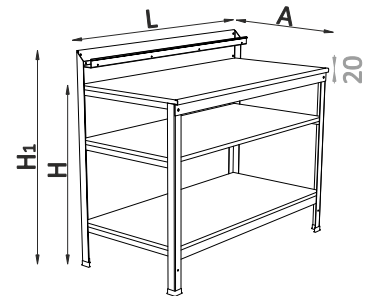

ENCIMERA
PLAN DE TRAVAIL
WORKTOP



Madera aglomerada
Bois aggloméré
Conglomerate wood

e 20 mm

		L x A x H (mm)	H 1 (mm)
137	42,6 Kg	1220x600x900	1050

e 2 mm



Montaje con tornillo (se entrega desmontado). Tornillos incluidos.
Montage avec vis (livraison démonté). Vis inclus.
Screw assembly (supplied disassembled). Included screws.

SERIE 137 STANDARD

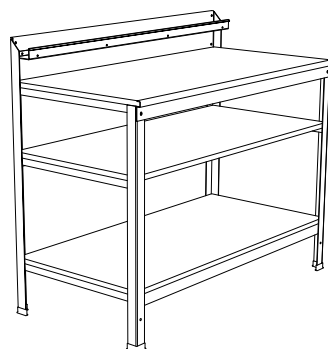

300

Carga total repartida.
Charge totale répartie.
Total distributed load.

		L x A x H
137	42,60 Kg	1220x600x900-1050

SERIE 142

new



600

Banco de trabajo ideal: calidad y robustez HECO simplificada sin perder la esencia .
Établi idéal :Qualité et robustesse des HECO simplifiées sans perdre l'essentiel.
Ideal workbench: HECO quality and robustness simplified without losing the essence.



Montaje fácil con tornillos.
Montage facile à l'aide de vis.
Easy assembly with screws.

A H min. 852 mm.
H max. 890 mm.

S H min. 722 mm.
H max. 760 mm.



Pies ajustables en altura.
Pieds réglables en hauteur
Feet adjustable in height.

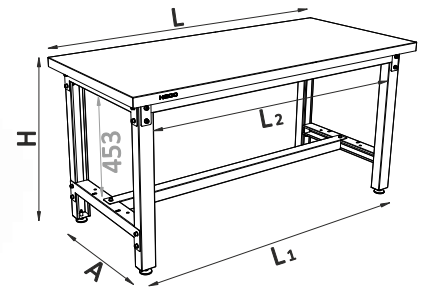

PIES PIEDS STANDS

INCLUYE:
Base redonda regulable en altura.
COMPREND:
Base ronde réglable en hauteur.
INCLUDES:
Height-adjustable round base.



ENCIMERA PLAN DE TRAVAIL WORKTOP

e 50 mm

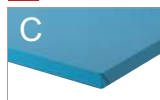

Chapa
Tôle
Metal

e 40 mm



D M
MDF
MDF

	L x A x H (mm)	L ₁ (mm)	L ₂ (mm)
142 15 S	1500 x 700 x 750	1400	1220
142 18 S	1800 x 700 x 750	1700	1520
142 20 S	2000 x 700 x 750	1900	1720
142 15 A	1500 x 700 x 880	1400	1220
142 18 A	1800 x 700 x 880	1700	1520
142 20 A	2000 x 700 x 880	1900	1720

OPCIÓN OPTIONNEL OPTION



PM

300 mm

Sistema elevación eléctrico.
Système d'élevation électrique.
Electrical Lift System.

ENCIMERA en opción
PLAN DE TRAVAIL en option
Option WORKTOP

e 12 mm



Compacto
Compact
Compact

e 1,5 mm CHAPA TÔLE / SHEET



Se entrega desmontado.
Livraison démonté.
Supplied disassembled.



Montaje con tornillo. Tornillos incluidos.
Montage avec vis. Vis inclus.
Screw assembly. Included screws.

SERIE 142 STANDARD



600

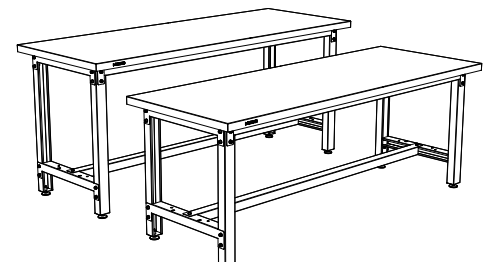
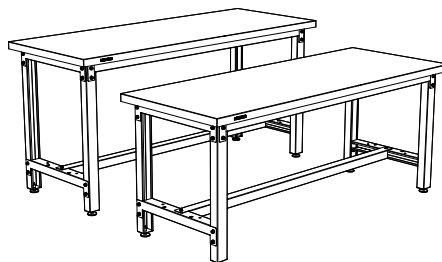
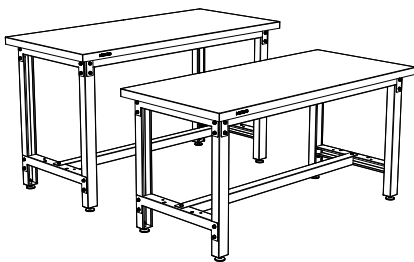

		LxAxH
142 15 S C	51,21 Kg	1500x700x760
142 15 S D	52,39 Kg	1500x700x750
142 15 A C	53,96 Kg	1500x700x890
142 15 A D	55,64 Kg	1500x700x880

		LxAxH
142 18 S C	56,36 Kg	1800x700x760
142 18 S D	58,37 Kg	1800x700x750
142 18 A C	59,61 Kg	1800x700x890
142 18 A D	61,62 Kg	1800x700x880

		LxAxH
142 20 S C	60,62 Kg	2000x700x760
142 20 S D	62,86 Kg	2000x700x750
142 20 A C	63,87 Kg	2000x700x890
142 20 A D	66,11 Kg	2000x700x880

SERIE 150 ref. 150 A / 150 P / 150 S

Bancos de trabajo configurables.
Établis configurables.
Customizable workbenches.



Carga total repartida.
Charge totale répartie.
Total distributed load.

1000



SERIE 150 S

Base para armario serie 110.
Support d'armoire série 110.
110 series cabinet base.

SERIE 150 P

Pestaña superior.
Onglet supérieur.
Upper tab.

SERIE 150 A

CAJONES TIROIRS DRAWERS

Cajones disponibles.
Tiroirs disponibles.
Available drawers.



129 / 132 / 133 / 113 / 153

OPCIONAL OPTION OPTION

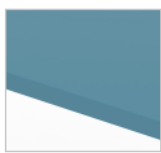

Chapa
Tôle
Metal



D M
MDF
MDF



M
Madera (castaño)
Bois (châtaigner)
Wood (chestnut)

e 50 mm

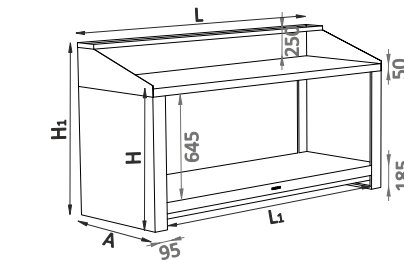
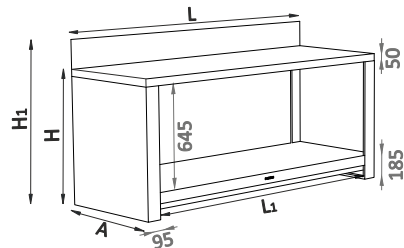
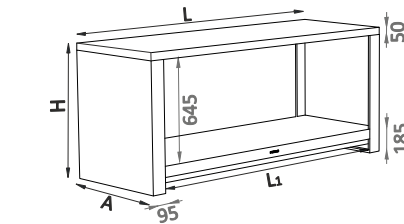

PIES PIEDS STANDS

Base redonda regulable en altura.
Base ronde réglable en hauteur.
Height-adjustable round base.



Montaje con tornillo (se entrega desmontado). Tornillos incluidos.
Montage avec vis (livraison démonté). Vis inclus.
Screw assembly (supplied disassembled). Included screws.

		L x A x H (mm)	L ₁ (mm)
150 10 A	81 Kg	1000x750x880	210
150 13 A	94 Kg	1300x750x880	1110
150 15 A	105 Kg	1500x750x880	1310
150 18 A	120 Kg	1800x750x880	1610
150 20 A	126 Kg	2000x750x880	1810

* Encimera de chapa Plan de travail tôle / Metal worktop

e 3 mm

		L x A x H x H ₁ (mm)	L ₁ (mm)
150 10 P	84 Kg	1000x750x880-1002	210
150 13 P	97 Kg	1300x750x880-1002	1110
150 15 P	109 Kg	1500x750x880-1002	1310
150 18 P	123 Kg	1800x750x880-1002	1610
150 20 P	134 Kg	2000x750x880-1002	1810

* Encimera de chapa Plan de travail tôle / Metal worktop

e 3 mm

		L x A x H x H ₁ (mm)	L ₁ (mm)
150 10 S	90 Kg	1000x750x880-1130	210
150 13 S	105 Kg	1300x750x880-1130	1110
150 15 S	116 Kg	1500x750x880-1130	1310
150 18 S	132 Kg	1800x750x880-1130	1610
150 20 S	142 Kg	2000x750x880-1130	1810

* Encimera de chapa Plan de travail tôle / Metal worktop

e 2 mm

SERIE 150 A STANDARD



Carga total repartida.
Charge totale répartie.
Total distributed load.

1000

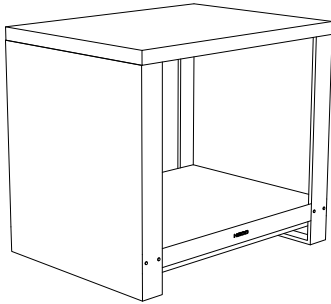

		L x A x H
150 10 A	81 Kg	1000x750x880
150 10 AD	82 Kg	1000x750x880
150 10 AM	77 Kg	1000x750x880

servicio / service / service

150 M 10 montaje / assemblage / set up

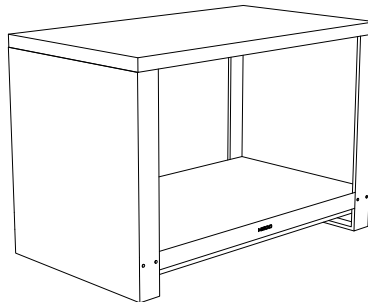

		L x A x H
150 13 A	94 Kg	1300x750x880
150 13 AD	94 Kg	1300x750x880
150 13 AM	90 Kg	1300x750x880

servicio / service / service

150 M 13 montaje / assemblage / set up

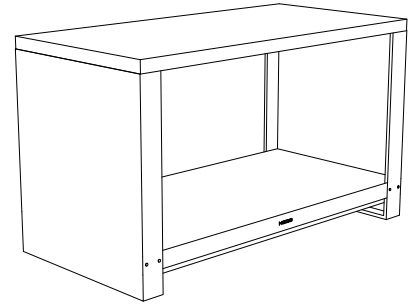

		L x A x H
150 15 A	105 Kg	1500x750x880
150 15 AD	103 Kg	1500x750x880
150 15 AM	100 Kg	1500x750x880

servicio / service / service

150 M 15 montaje / assemblage / set up

SERIE 109 13

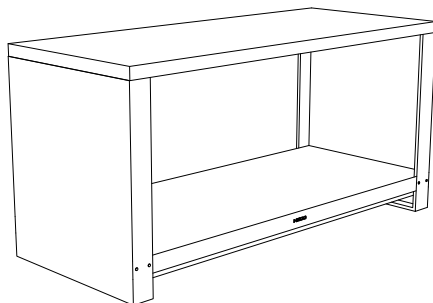

		L x A x H
150 18 A	120 Kg	1800x750x880
150 18 AD	117 Kg	1800x750x880
150 18 AM	112 Kg	1800x750x880

servicio / service / service

150 M 18 montaje / assemblage / set up

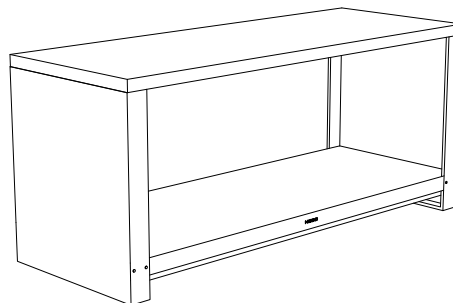

		L x A x H
150 20 A	126 Kg	2000x750x880
150 20 AD	129 Kg	2000x750x880
150 20 AM	120 Kg	2000x750x880

servicio / service / service

150 M 20 montaje / assemblage / set up

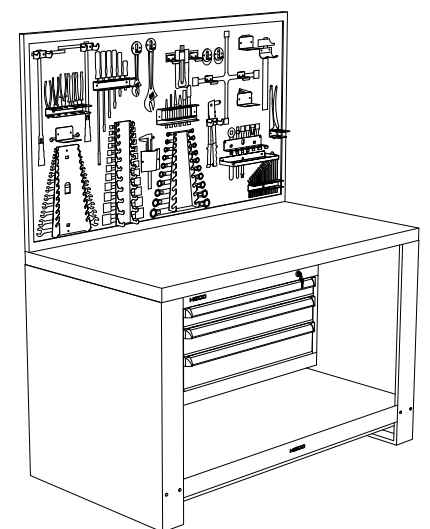

SERIE 113 3

SERIE 150 13 M

Solución Solution Solution

SERIE 150 P STANDARD



Carga total repartida.
Charge totale répartie.
Total distributed load.

1000

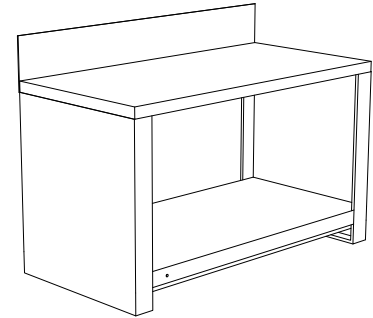
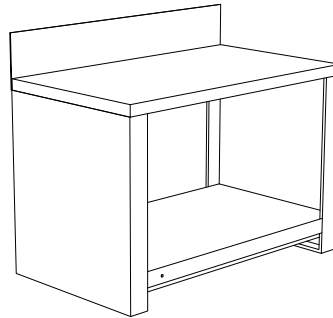
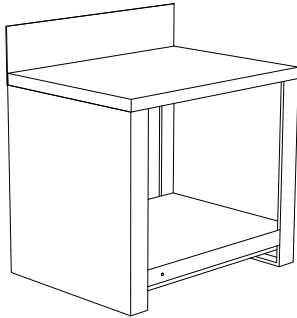

		L x A x H
150 10 P	84 Kg	1000x750x880
150 10 PD	85 Kg	1000x750x880
150 10 PM	80 Kg	1000x750x880

		L x A x H
150 13 P	97 Kg	1300x750x880
150 13 PD	97 Kg	1300x750x880
150 13 PM	93 Kg	1300x750x880

		L x A x H
150 15 P	109 Kg	1500x750x880
150 15 PD	107 Kg	1500x750x880
150 15 PM	104 Kg	1500x750x880

servicio / service / service		
150 M 10	montaje / assemblage / set up	
	L x A x H (mm)	VOL (m ³)
1	1030x270x770	0,214

servicio / service / service		
150 M 13	montaje / assemblage / set up	
	L x A x H (mm)	VOL (m ³)
1	1330x270x770	0,277

servicio / service / service		
150 M 15	montaje / assemblage / set up	
	L x A x H (mm)	VOL (m ³)
1	1530x270x770	0,318

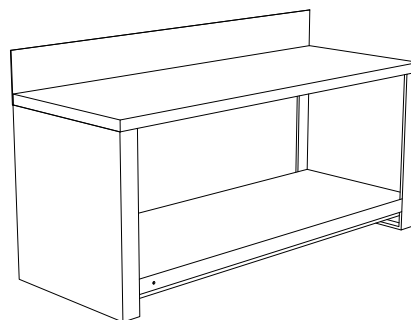
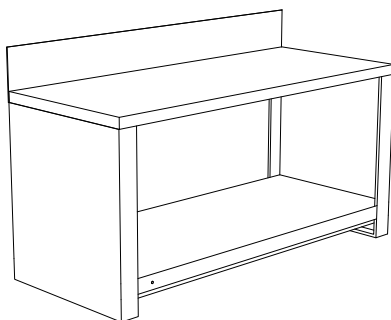

SERIE 150 18 P

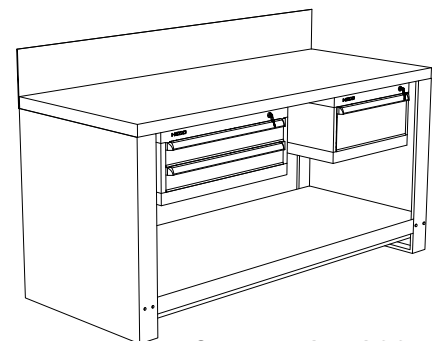

SERIE 153 1 200

SERIE 113 2

		L x A x H
150 18 P	123 Kg	1800x750x880
150 18 PD	120 Kg	1800x750x880
150 18 PM	115 Kg	1800x750x880

		L x A x H
150 20 P	134 Kg	2000x750x880
150 20 PD	134 Kg	2000x750x880
150 20 PM	125 Kg	2000x750x880

servicio / service / service		
150 M 18	montaje / assemblage / set up	
	L x A x H (mm)	VOL (m ³)
1	1830x270x770	0,380

servicio / service / service		
150 M 20	montaje / assemblage / set up	
	L x A x H (mm)	VOL (m ³)
1	2030x270x770	0,422

Solución Solution Solution

SERIE 150 S STANDARD



Carga total repartida.
Charge totale répartie.
Total distributed load.

1000

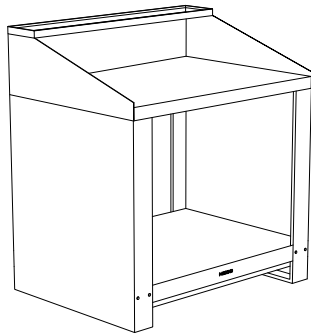

		L x A x H
150 10 S	90 Kg	1000x750x880
150 10 SD	97 Kg	1000x750x880
150 10 SM	92 Kg	1000x750x880

servicio / service / service
150 M 10 montaje / assemblage / set up

	L x A x H (mm)	VOL (m³)
1	1040x280x780	0,227

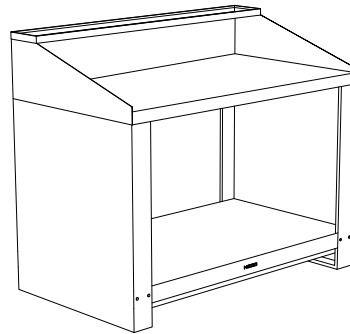

		L x A x H
150 13 S	105 Kg	1300x750x880
150 13 SD	111 Kg	1300x750x880
150 13 SM	107 Kg	1300x750x880

servicio / service / service
150 M 13 montaje / assemblage / set up

	L x A x H (mm)	VOL (m³)
1	1340x280x780	0,293

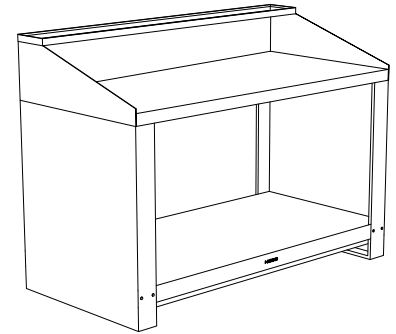

		L x A x H
150 15 S	116 Kg	1500x750x880
150 15 SD	121 Kg	1500x750x880
150 15 SM	118 Kg	1500x750x880

servicio / service / service
150 M 15 montaje / assemblage / set up

	L x A x H (mm)	VOL (m³)
1	1540x280x780	0,336

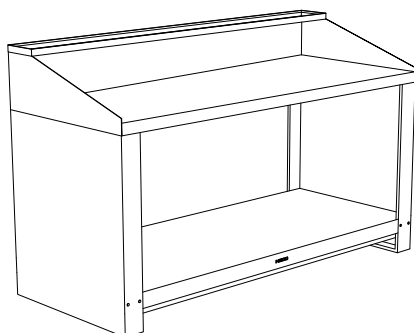

		L x A x H
150 18 S	132 Kg	1800x750x880
150 18 SD	137 Kg	1800x750x880
150 18 SM	132 Kg	1800x750x880

servicio / service / service
150 M 18 montaje / assemblage / set up

	L x A x H (mm)	VOL (m³)
1	1840x280x780	0,402

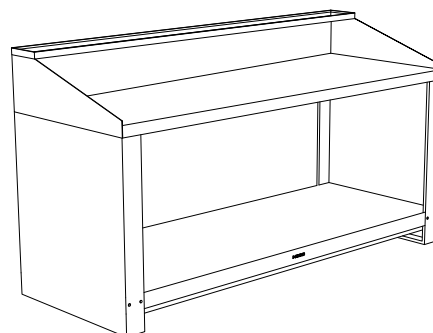

		L x A x H
150 20 S	142 Kg	2000x750x880
150 20 SD	151 Kg	2000x750x880
150 20 SM	142 Kg	2000x750x880

servicio / service / service
150 M 20 montaje / assemblage / set up

	L x A x H (mm)	VOL (m³)
1	2040x280x780	0,402

SERIE 110 18 1

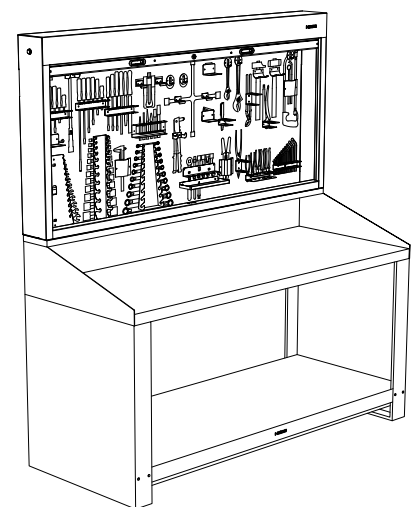

SERIE 150 18 S

Solución Solution Solution

SERIE 150

Conjunto banco de trabajo y armario con persiana + tablero serigrafiado / perforado.
 Ensemble établi et armoire à rideau + panneau sérigraphié ou perforé.
 Workbench with shuttered cabinet + screen printed or perforated panel.



SERIE 150 S + 110 4



Con panel perforado.
 Avec panneau perforé.
 With perforated panel.

SERIE 150 S + 110 1



Con panel serigrafiado.
 Avec panneau sérigraphié.
 With screen printed panel.

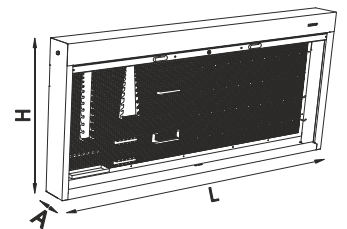
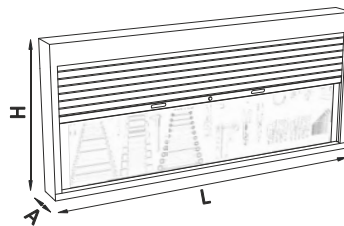

	110 1	110 4	L x A x H (mm)
110 10	32 Kg	36,5 Kg	1000x170x900
110 13	38 Kg	51 Kg	1300x170x900
110 15	41 Kg	64,8 Kg	1500x170x900
110 18	48 Kg	66,5 Kg	1800x170x900
110 20	52 Kg	72 Kg	2000x170x900

OPCIONAL OPTION OPTION

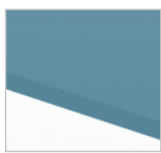

Chapa
Tôle
Metal



D M
MDF
MDF



Madera (castaño)
Bois (châtaigner)
Wood (chestnut)

e 50 mm

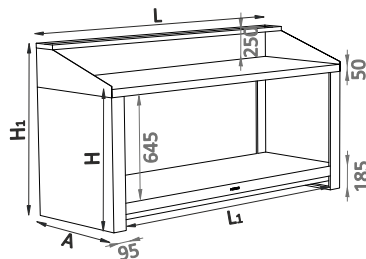

PIES PIEDS STANDS

Base redonda regulable en altura.
 Base ronde réglable en hauteur.
 Height-adjustable round base.



e 1 mm



Para más información sobre armarios murales, ver PAG.105.
 Pour plus d'information sur les armoires murales, voir PAGE 105.
 For further information on wall-hung cabinets, see PAGE 105.

		L x A x H x H ₁ (mm)	L ₁ (mm)
150 10 S	90 Kg	1000x750x880-1130	810
150 13 S	105 Kg	1300x750x880-1130	1110
150 15 S	116 Kg	1500x750x880-1130	1310
150 18 S	132 Kg	1800x750x880-1130	1610
150 20 S	142 Kg	2000x750x880-1130	1810

* Encimera de chapa Plan de travail tôle / Metal worktop

e 2 mm



Montaje con tornillo (se entrega desmontado). Tornillos incluidos.
 Montage avec vis (livraison démonté). Vis inclus.
 Screw assembly (supplied disassembled). Included screws.

SERIE 150 STANDARD

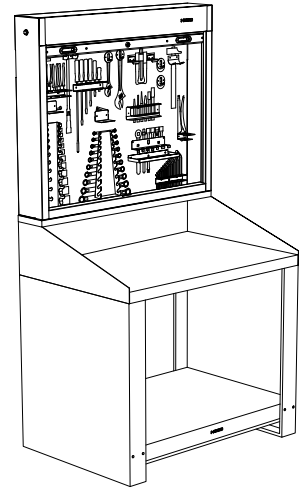
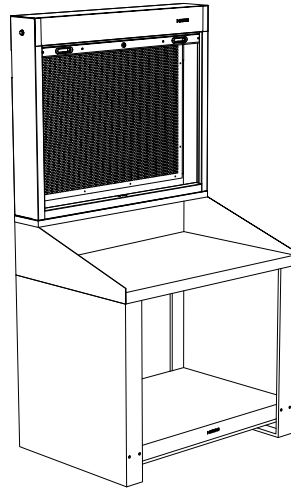
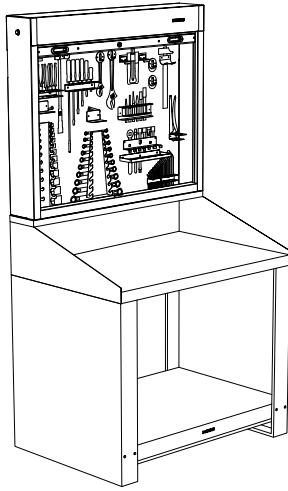

150 10 1



		L x A x H
150 10 S	90 Kg	1000x750x880
110 10 1	32 Kg	1000x170x900

servicio / service / service

150 M 10 montaje / assemblage / set up

* Encimera de chapa Plan de travail tôle / Metal worktop

150 10 2



		L x A x H
150 10 S	90 Kg	1000x750x880
110 10 4	36,5 Kg	1000x170x900

servicio / service / service

150 M 10 montaje / assemblage / set up

* Encimera de chapa Plan de travail tôle / Metal worktop

150 10 3



		L x A x H
150 10 SD	97 Kg	1000x750x880
110 10 1	32 Kg	1000x170x900

servicio / service / service

150 M 10 montaje / assemblage / set up

* Encimera de DM Plan de travail MDF / MDF worktop

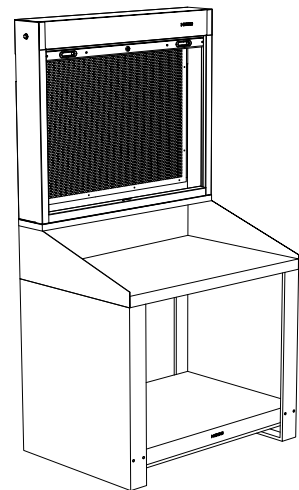
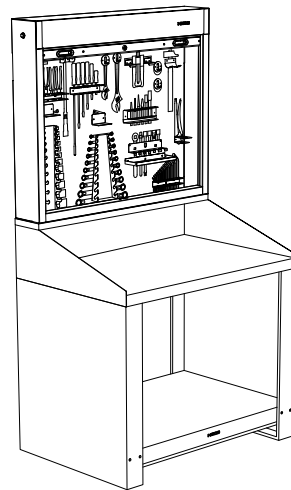
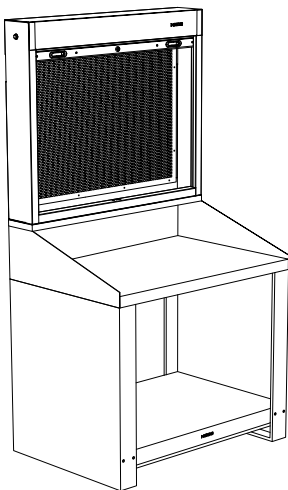

150 10 4



		L x A x H
150 10 SD	97 Kg	1000x750x880
110 10 4	36,5 Kg	1000x170x900

servicio / service / service

150 M 10 montaje / assemblage / set up

* Encimera de DM Plan de travail MDF / MDF worktop

150 10 5



		L x A x H
150 10 SM	92 Kg	1000x750x880
110 10 1	32 Kg	1000x170x900

servicio / service / service

150 M 10 montaje / assemblage / set up

* Encimera de madera Plan de travail bois / Wood worktop

150 10 6



		L x A x H
150 10 SM	97 Kg	1000x750x880
110 10 4	36,5 Kg	1000x170x900

servicio / service / service

150 M 10 montaje / assemblage / set up

* Encimera de madera Plan de travail bois / Wood worktop

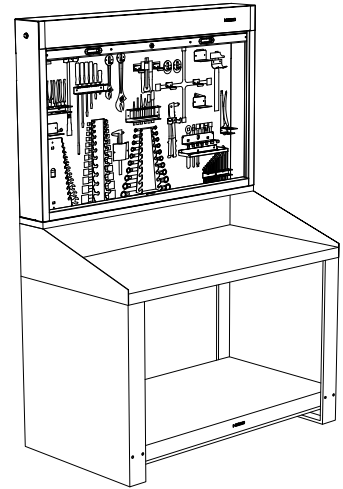
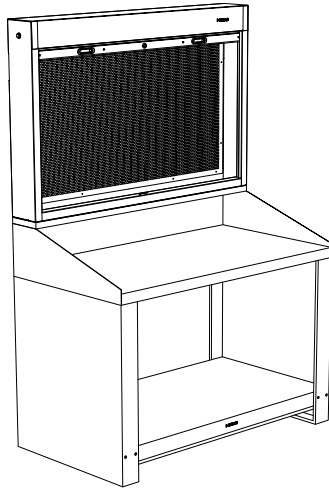
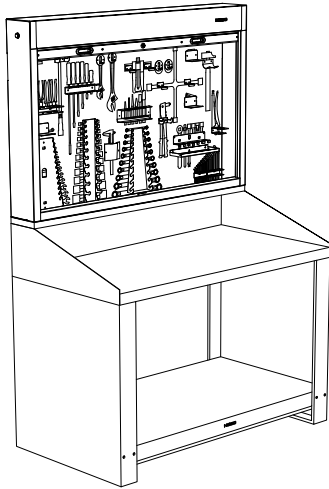

150 13 1



		L x A x H
150 13 S	105 Kg	1300x750x880
110 13 1	38 Kg	1300x170x900

servicio / service / service

150 M 13 montaje / assemblage / set up

* Encimera de chapa Plan de travail tôle / Metal worktop

150 13 2



		L x A x H
150 13 S	105 Kg	1300x750x880
110 13 4	51 Kg	1300x170x900

servicio / service / service

150 M 13 montaje / assemblage / set up

* Encimera de chapa Plan de travail tôle / Metal worktop

150 13 3



		L x A x H
150 13 SD	111 Kg	1300x750x880
110 11 1	38 Kg	1300x170x900

servicio / service / service

150 M 13 montaje / assemblage / set up

* Encimera de DM Plan de travail MDF / MDF worktop

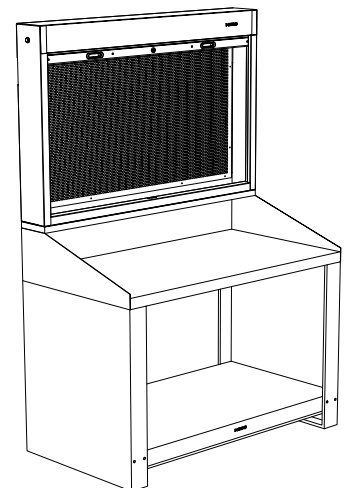
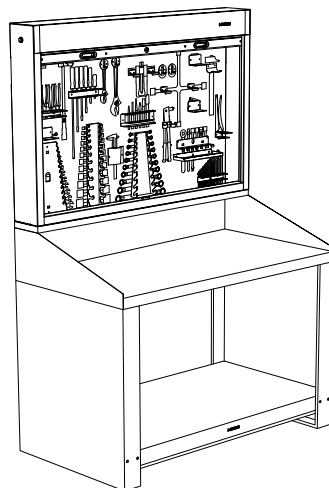
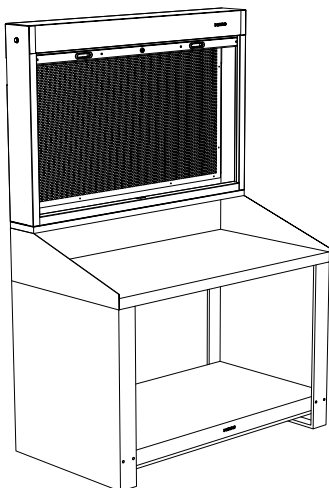

150 13 4



		L x A x H
150 13 SD	111 Kg	1300x750x880
110 13 4	51 Kg	1300x170x900

servicio / service / service

150 M 13 montaje / assemblage / set up

* Encimera de DM Plan de travail MDF / MDF worktop

150 13 5



		L x A x H
150 13 SM	107 Kg	1300x750x880
110 13 1	38 Kg	1300x170x900

servicio / service / service

150 M 13 montaje / assemblage / set up

* Encimera de madera Plan de travail bois / Wood worktop

150 13 6



		L x A x H
150 16 SM	107 Kg	1300x750x880
110 13 4	51 Kg	1300x170x900

servicio / service / service

150 M 13 montaje / assemblage / set up

* Encimera de madera Plan de travail bois / Wood worktop

SERIE 150 STANDARD

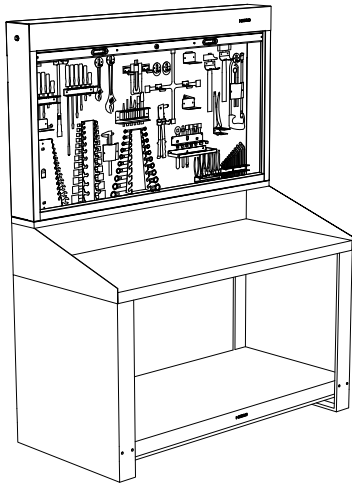

150 15 1



		L x A x H
150 15 S	116 Kg	1500x750x880
110 15 1	41 Kg	1500x170x900

servicio / service / service

150 M 15 montaje / assemblage / set up

* Encimera de chapa Plan de travail tôle / Metal worktop

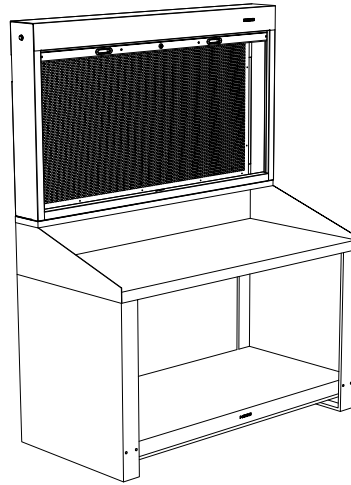

150 15 2



		L x A x H
150 15 S	116 Kg	1500x750x880
110 15 4	64,8 Kg	1500x170x900

servicio / service / service

150 M 15 montaje / assemblage / set up

* Encimera de chapa Plan de travail tôle / Metal worktop

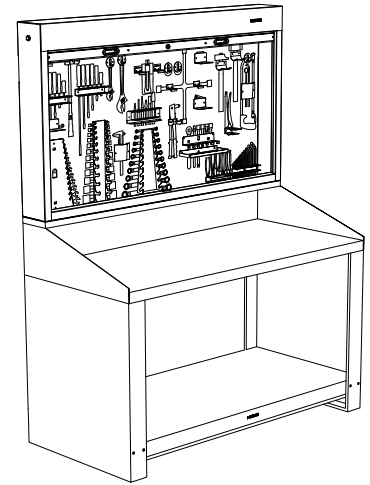

150 15 3



		L x A x H
150 15 SD	121 Kg	1500x750x880
110 15 1	41 Kg	1500x170x900

servicio / service / service

150 M 15 montaje / assemblage / set up

* Encimera de DM Plan de travail MDF / MDF worktop

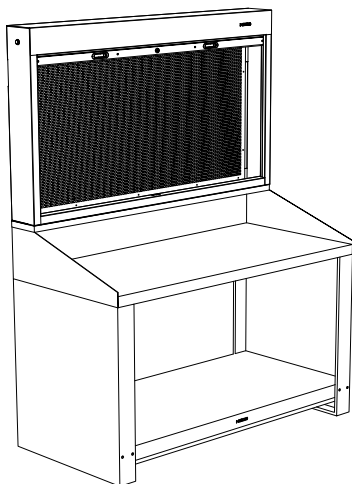

150 15 4



		L x A x H
150 15 SD	121 Kg	1500x750x880
110 15 4	64,8 Kg	1500x170x900

servicio / service / service

150 M 15 montaje / assemblage / set up

* Encimera de DM Plan de travail MDF / MDF worktop

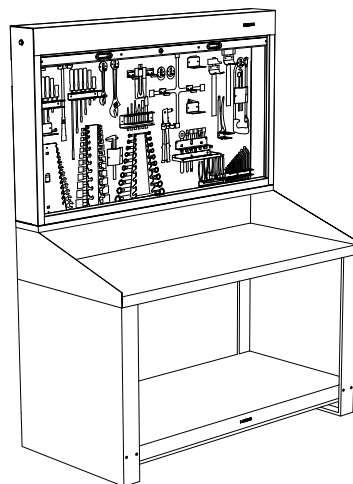

150 15 5



		L x A x H
150 15 SM	118 Kg	1500x750x880
110 15 1	41 Kg	1500x170x900

servicio / service / service

150 M 15 montaje / assemblage / set up

* Encimera de madera Plan de travail bois / Wood worktop

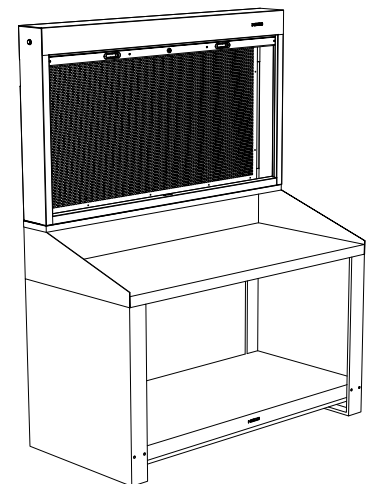

150 15 6



		L x A x H
150 15 SM	118 Kg	1500x750x880
110 15 4	64,8 Kg	1500x170x900

servicio / service / service

150 M 15 montaje / assemblage / set up

* Encimera de madera Plan de travail bois / Wood worktop

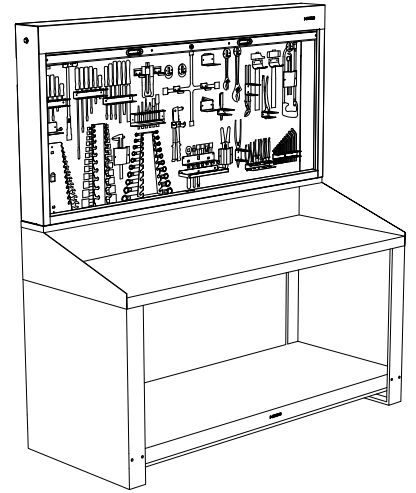
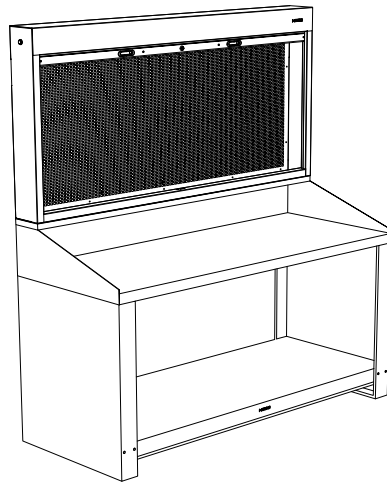
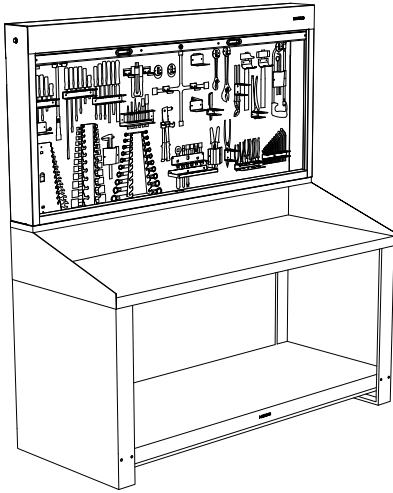

150 18 1



		L x A x H
150 18 S	132 Kg	1800x750x880
110 18 1	48 Kg	1800x170x900

servicio / service / service

150 M 18 montaje / assemblage / set up

* Encimera de chapa Plan de travail tôle / Metal worktop

150 18 2



		L x A x H
150 18 S	116 Kg	1800x750x880
110 18 4	66,5 Kg	1800x170x900

servicio / service / service

150 M 18 montaje / assemblage / set up

* Encimera de chapa Plan de travail tôle / Metal worktop

150 18 3



		L x A x H
150 18 SD	137 Kg	1800x750x880
110 18 1	48 Kg	1800x170x900

servicio / service / service

150 M 18 montaje / assemblage / set up

* Encimera de DM Plan de travail MDF / MDF worktop

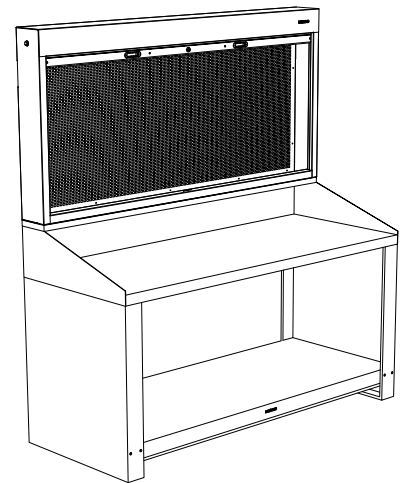
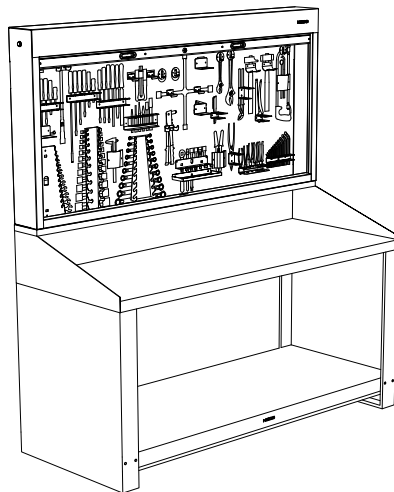
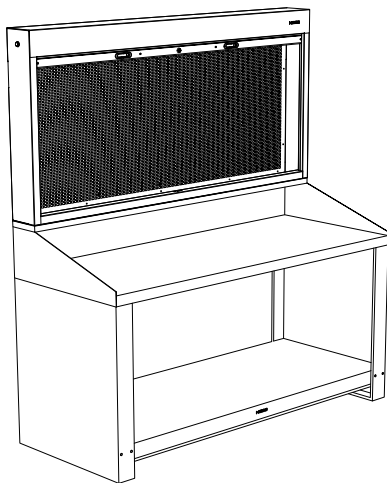

150 18 4



		L x A x H
150 18 SD	137 Kg	1800x750x880
110 18 4	66,5 Kg	1800x170x900

servicio / service / service

150 M 18 montaje / assemblage / set up

* Encimera de DM Plan de travail MDF / MDF worktop

150 18 5



		L x A x H
150 18 SM	132 Kg	1800x750x880
110 18 1	48 Kg	1800x170x900

servicio / service / service

150 M 18 montaje / assemblage / set up

* Encimera de madera Plan de travail bois / Wood worktop

150 18 6



		L x A x H
150 18 SM	132 Kg	1800x750x880
110 18 4	66,5 Kg	1800x170x900

servicio / service / service

150 M 18 montaje / assemblage / set up

* Encimera de madera Plan de travail bois / Wood worktop

SERIE 150 STANDARD

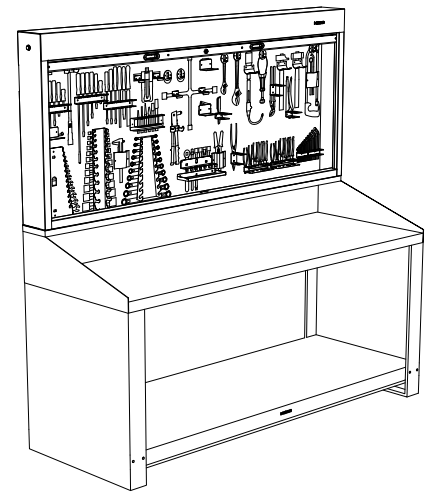
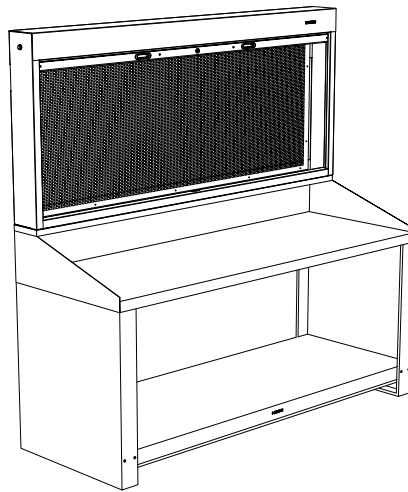
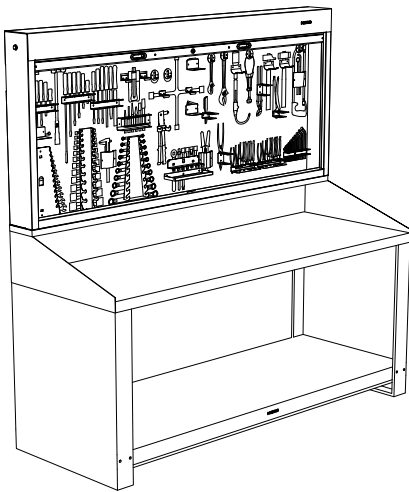

150 20 1



L x A x H		
150 20 S	142 Kg	2000x750x880
110 20 1	52 Kg	2000x170x900

servicio / service / service

150 M 20 montaje / assemblage / set up

* Encimera de chapa Plan de travail tôle / Metal worktop

150 20 2



L x A x H		
150 20 S	142 Kg	2000x750x880
110 20 4	72 Kg	2000x170x900

servicio / service / service

150 M 20 montaje / assemblage / set up

* Encimera de chapa Plan de travail tôle / Metal worktop

150 20 3



L x A x H		
150 20 SD	151 Kg	2000x750x880
110 20 1	52 Kg	2000x170x900

servicio / service / service

150 M 20 montaje / assemblage / set up

* Encimera de DM Plan de travail MDF / MDF worktop

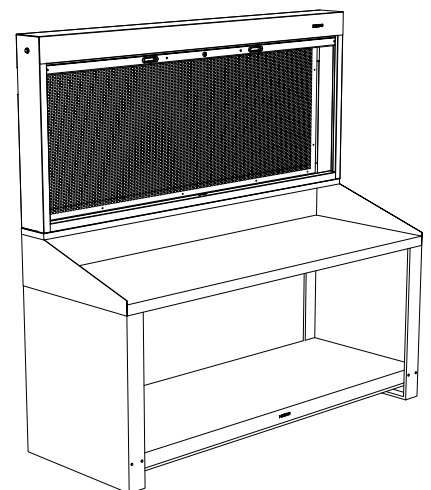
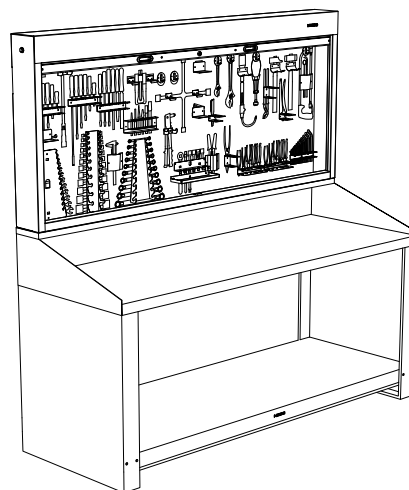
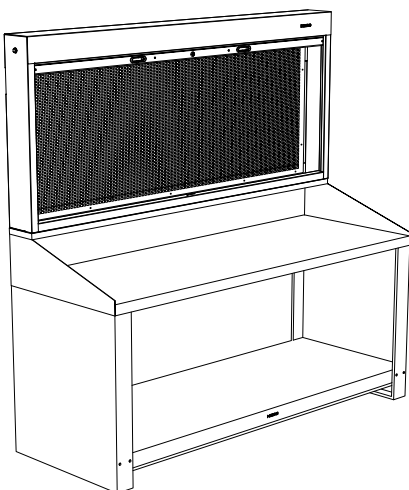

150 20 4



L x A x H		
150 20 SD	151 Kg	2000x750x880
110 20 4	72 Kg	2000x170x900

servicio / service / service

150 M 20 montaje / assemblage / set up

* Encimera de DM Plan de travail MDF / MDF worktop

150 20 5



L x A x H		
150 20 SM	142 Kg	2000x750x880
110 20 1	52 Kg	2000x170x900

servicio / service / service

150 M 20 montaje / assemblage / set up

* Encimera de madera Plan de travail bois / Wood worktop

150 20 6



L x A x H		
150 20 SM	142 Kg	2000x750x880
110 20 4	72 Kg	2000x170x900

servicio / service / service

150 M 20 montaje / assemblage / set up

* Encimera de madera Plan de travail bois / Wood worktop

SERIE 152 ref. 152 10 / 152 15 / 152 20

Bancos de trabajo monobloque: totalmente soldado.
Établis monobloc: entièrement soudé.
Customizable fully-welded monoblock workbenches.



Carga total repartida.
Charge totale répartie.
Total distributed load.

2000

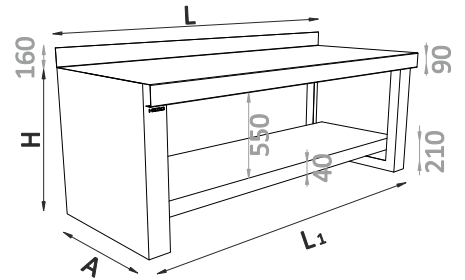

CAJONES TIROIRS DRAWERS

Cajones disponibles.
Tiroirs disponibles.
Available drawers.



129 / 132 / 133 / 113 / 153

PIES PIEDS STANDS

INCLUYE:
Base redonda regulable en altura.
COMPREND:
Base ronde réglable en hauteur.
INCLUDES:
Height-adjustable round base.



		L x A x H (mm)	L ₁ (mm)
152 10	82 Kg	1000x750x900	810
152 15	110 Kg	1500x750x900	1310
152 20	138 Kg	2000x750x900	1810

e 5 mm Encimera Plan de travail / Worktop

SERIE 152 STANDARD

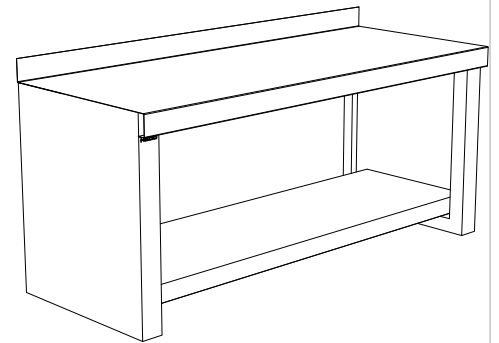
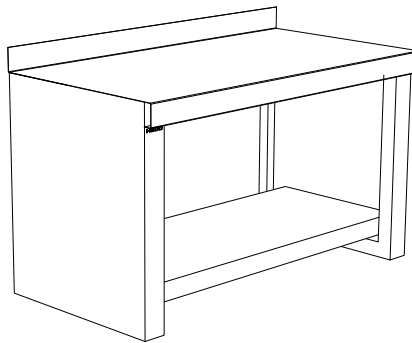
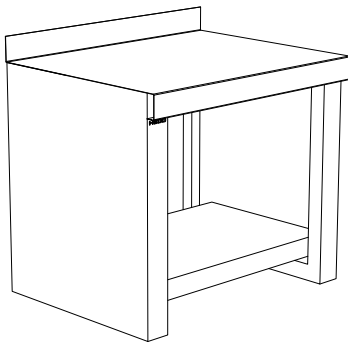

		L x A x H
152 10	82 Kg	1000x750x1060
	L x A x H (mm)	VOL (m ³)
1	1030x780x895	0,719

		L x A x H
152 15	110 Kg	1500x750x1060
	L x A x H (mm)	VOL (m ³)
1	1530x780x895	1,068

		L x A x H
152 20	138 Kg	2000x750x1060
	L x A x H (mm)	VOL (m ³)
1	1830x780x895	1,278

SERIE 129 - 132 - 133

Para bancos de trabajo 112 / 150 / 152.
Pour établis 112 / 150 / 152.
For 112 / 150 / 152 workbenches.



SERIE 129



SERIE 132



SERIE 133



Especificar tipo de encimera.
Spécifier type du plan de travail.
Specify type of worktop.

SERIE 129 STANDARD

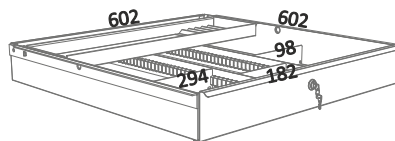
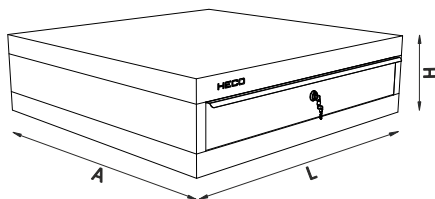

		L x A x H
129	34,9 Kg	714x707x300
	L x A x H (mm)	VOL (m³)
1	725x770x325	0,181



Incluye bandeja interior deslizante y extraíble, y divisiones según dibujo.
Comprend un plateau intérieur coulissant et amovible et des divisions selon le dessin.
Includes sliding and removable inner tray and divisions according to drawing.

SERIE 132 STANDARD

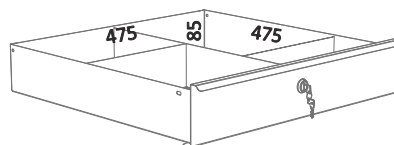
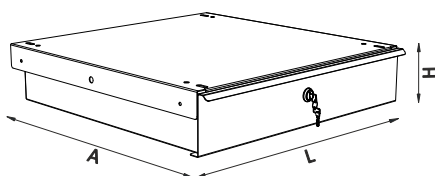

		L x A x H
132	9 Kg	500x500x105
	L x A x H (mm)	VOL (m³)
1	530x530x135	0,038



Incluye divisiones según dibujo.
Comprend des divisions selon le dessin.
Includes divisions according to drawing.

SERIE 133 STANDARD

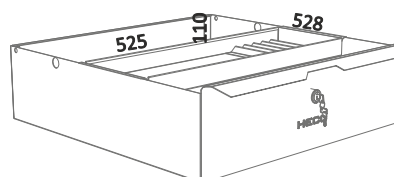
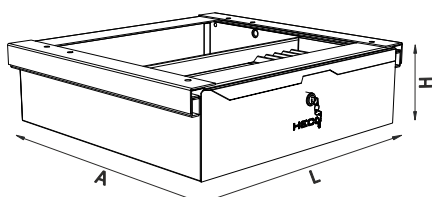

		L x A x H
133	8 Kg	570x528x160
	L x A x H (mm)	VOL (m³)
1	600x590x180	0,064



Incluye bandeja interior deslizante y extraíble.
Comprend un plateau intérieur coulissant et amovible.
Includes sliding and removable inner tray.

SERIE 153

Para bancos de trabajo 112 / 150 / 152.
 Pour établis 112 / 150 / 152.
 For 112 / 150 / 152 workbenches.

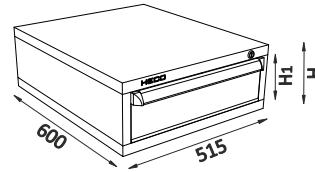

	H1 (mm)	H (mm)
153 1 100	100	200
153 1 200	200	300
153 2	200	300
153 3	300	400
153 4	400	500

e 1 mm estructura structure / structure

e 1,5 mm cajón tiroir / drawer

i Especificar tipo de encimera.
 Spécifier type du plan de travail.
 Specify type of worktop.

SERIE 153 STANDARD



Por cajón.
 Pour tiroir.
 For drawer.

100

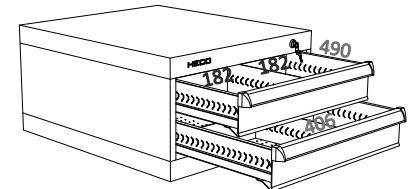
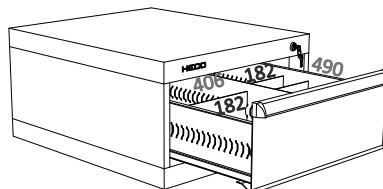
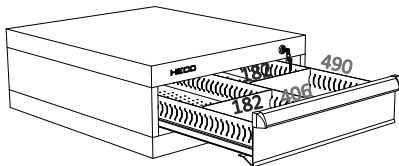

L x A x H		
153 1 100	18 Kg	515x600x200
	L x A x H (mm)	VOL (m³)
1	530x650x210	0,070

L x A x H		
153 1 200	21 Kg	515x600x300
	L x A x H (mm)	VOL (m³)
1	530x650x310	0,103

L x A x H		
153 2	24 Kg	515x600x300
	L x A x H (mm)	VOL (m³)
1	530x650x310	0,103

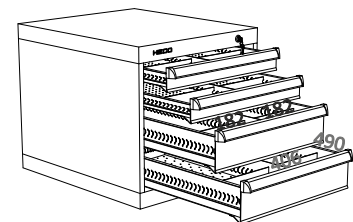
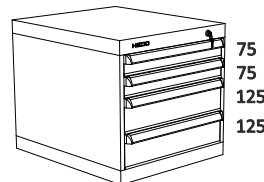
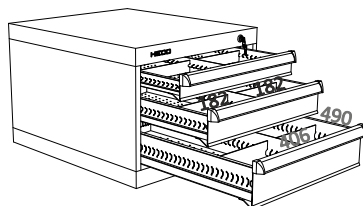
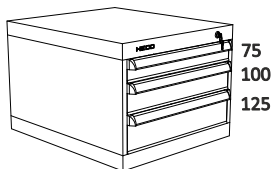

L x A x H		
153 3	37,5 Kg	515x600x400
	L x A x H (mm)	VOL (m³)
1	530x650x410	0,136

L x A x H		
153 4	43 Kg	515x600x500
	L x A x H (mm)	VOL (m³)
1	530x650x510	0,228

SERIE 113

Para bancos de trabajo 112 / 150 / 152.
Pour établis 112 / 150 / 152.
For 112 / 150 / 152 workbenches.

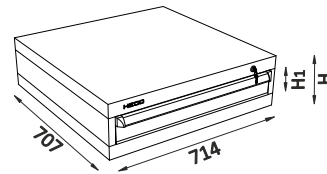

100

	H1 (mm)	H (mm)
113 1 100	100	200
113 1 200	200	300
113 2	200	300
113 3	300	400
113 4	400	500

e 1 mm estructura structure / structure

e 1,5 mm cajón tiroir / drawer



Especificar tipo de encimera.
Spécifier type du plan de travail.
Specify type of worktop.

SERIE 113 STANDARD



Por cajón.
Pour tiroir.
For drawer.

100

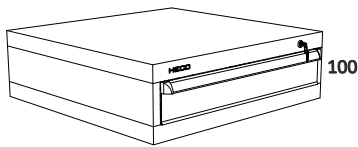

100

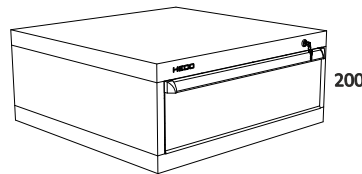

200

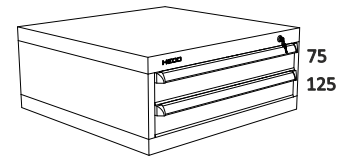

75
125

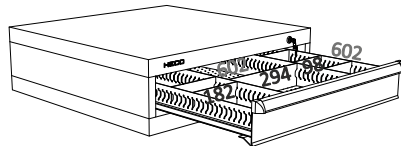

602

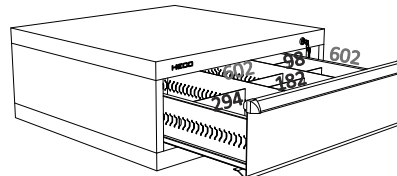

602

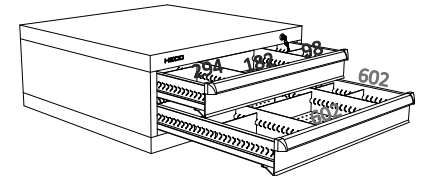

602

L x A x H		
113 1 100	28 Kg	714x707x200
	L x A x H (mm)	VOL (m³)
1	730x755x125	0,122

L x A x H		
113 1 200	29 Kg	714x707x300
	L x A x H (mm)	VOL (m³)
1	730x735x325	0,174

L x A x H		
113 2	37 Kg	714x707x300
	L x A x H (mm)	VOL (m³)
1	740x735x325	0,174

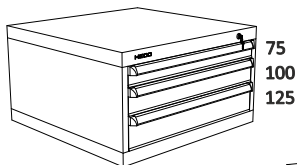

75
100
125

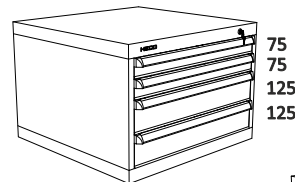

75
75
125
125

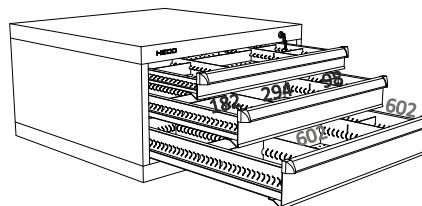

602

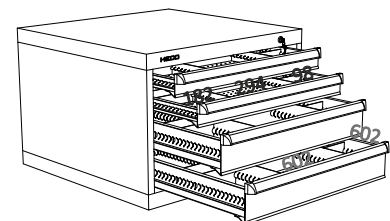

602

L x A x H		
113 3	60 Kg	714x707x400
	L x A x H (mm)	VOL (m³)
1	740x735x425	0,231

L x A x H		
113 4	76 Kg	714x707x500
	L x A x H (mm)	VOL (m³)
1	740x735x525	0,285

